

# High resolution X-ray imaging system

Selectable optimized components  
for various applications of synchrotron radiation imaging



The high resolution X-ray imaging system is designed for the application of X-ray imaging in synchrotron radiation facilities. Real-time X-ray phenomena can be imaged by combining an imaging unit that uses a phosphor to visualize an incident X-ray beam, and Hamamatsu's digital camera.

With an optical design that reduces damage to the detector due to X-rays as well as a dedicated camera mounting mechanism that facilitates the replacement of cameras, an optimal system of components for various applications of synchrotron radiation imaging can be established.

## FEATURES

- X-ray proof design
- Exchange of phosphors by the attachment structure
- Focus adjustment with the controller
- One touch design for camera attachment
- High-durability single-crystal phosphor screen (Option)

## APPLICATIONS

- Synchrotron imaging
- X-ray beam alignment
- X-ray CT
- X-ray microscope
- X-ray topography
- XAFS

# Imaging unit selection

There are two types of imaging units: a large area type that has both spatial resolution and effective field of view in a high level of balance, and a microscopic type that specializes in spatial resolution and is able to identify 1  $\mu\text{m}$  line and space or less. An imaging unit can be selected in accordance with the desired resolution.

## Large area type

For the large area type imaging unit, a lens attachment is used to attach a camera.  
(Please refer to page 6 for cameras and lens attachments.)

Correlation diagram of spatial resolution and effective field of view (reference data)

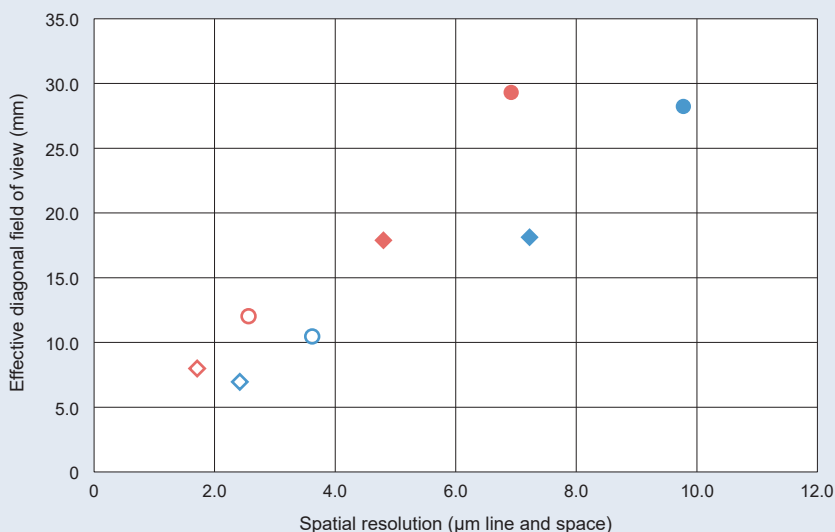

	Imaging unit	Camera	Lens attachment
◆	M11427-43 AA41	ORCA®-Quest	A11444-8050
◇			A11444-8135A
◆		ORCA®-Flash4.0 V3	A11444-4050
◇			A11444-4135A
●	M11427-62 AA60	ORCA®-Quest	A11444-8050
○			A11444-8135A
●		ORCA®-Flash4.0 V3	A11444-4050
○			A11444-4135A

\* The spatial resolution and effective field of view in the above diagram are examples of actual values measured with visible light without a phosphor. Please refer to it as reference data.  
Please contact Hamamatsu for detailed measurement conditions.

## Microscopic type

For the microscopic type imaging unit, a camera is attached with a C-mount or F-mount. Lens attachments are not used.  
(Please refer to page 6 for cameras.)

Correlation diagram of spatial resolution and effective field of view (reference data)

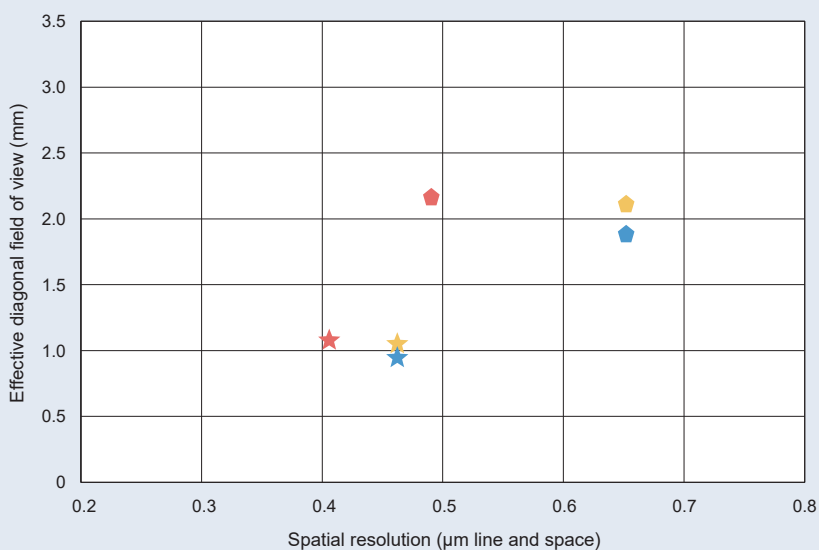

	Imaging unit	Camera
◆	M11427-57 AA51	ORCA®-Quest
◆		ORCA®-Flash4.0 V3
◆		ORCA®-Fusion
★	M11427-58 AA51	ORCA®-Quest
★		ORCA®-Flash4.0 V3
★		ORCA®-Fusion

\* The spatial resolution and effective field of view in the above diagram are examples of actual values measured with visible light without a phosphor. Please refer to it as reference data.  
Please contact Hamamatsu for detailed measurement conditions.

# Imaging unit Large area type

## • High resolution X-ray imaging system AA41 (50 mm) M11427-43

By using the base material of phosphor also for the input window material, higher resolution and detection of X-rays with lower energy are achieved.



### Specifications

Product number	M11427-43
Input window material	Be (0.5 mm)
X-ray energy	3 keV or higher
Phosphor effective diameter	16 mm
Phosphor material	P43 (Gd <sub>2</sub> O <sub>2</sub> S: Tb)
Peak emission wavelength	540 nm
Decay time	1 ms
Thickness of phosphor (typ.)	10 μm
Base material of phosphor	Be (0.5 mm)
Spatial resolution *1	8 μm
1st lens	50 mm (F1.2)
2nd lens *2	50 mm (F1.2)
	75 mm (F2.8)
	135 mm (F1.8)
ND filter	—

\*1 Reference value with ORCA®-Flash4.0 V3. It varies depending on the system configuration.

\*2 To be selected by lens attachment. (See page 6)

### Light path

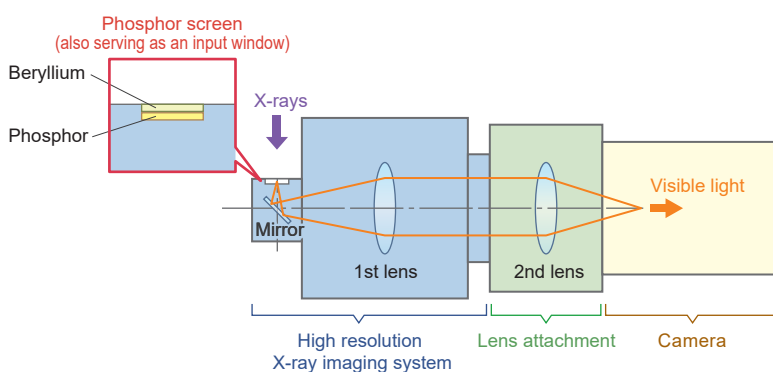

\* For the components of the imaging optical system, browning may be caused due to X-ray irradiation, resulting in a decrease in transmittance.

## • High resolution X-ray imaging system AA60 M11427-62

The effective diameter of the 35 mm phosphor is suitable for wide-field imaging.

By selecting the optical system, an area larger than the effective area of the camera can be imaged.



### Specifications

Product number	M11427-62
Input window material	Amorphous carbon (0.5 mm)
X-ray energy	6 keV or higher
Phosphor effective diameter	35 mm
Phosphor material	P43 (Gd <sub>2</sub> O <sub>2</sub> S: Tb)
Peak emission wavelength	540 nm
Decay time	1 ms
Thickness of phosphor (typ.)	10 μm
Base material of phosphor	quartz (5 mm)
Spatial resolution *1	10 μm or higher
1st lens	75 mm (F2.8)
2nd lens *2	50 mm (F1.2)
	75 mm (F2.8)
	135 mm (F1.8)
ND filter	ND-10 / ND-1

\*1 Reference value with ORCA®-Flash4.0 V3. It varies depending on the system configuration.

\*2 To be selected by lens attachment. (See page 6)

### Light path

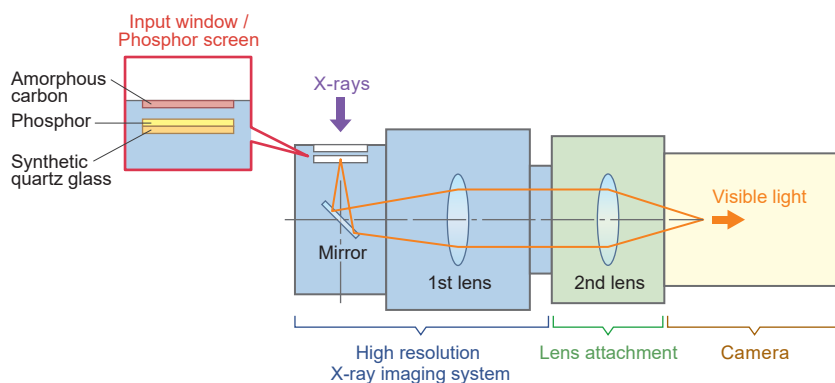

\* For the components of the imaging optical system, browning may be caused due to X-ray irradiation, resulting in a decrease in transmittance.

# Imaging unit Microscopic type

## ● High resolution X-ray imaging system AA51 M11427-57B, -57S, -58B, -58S

High-resolution images can be acquired by forming an image on the camera through a high NA objective lens and an infinity-corrected optical system. The phosphor screen can be selected separately from among the options.

In addition, the cable connection position can be selected from two patterns, side panel and back panel, depending on the space for installation.

- M11427-57B, -58B: Back panel
- M11427-57S, -58S: Side panel



### Specifications

Product number	M11427-57B, -57S	M11427-58B, -58S
Input window material	-	
X-ray energy	6 keV or higher	
Phosphor effective diameter	Refer to specifications for phosphor screens (below)	
Phosphor material		
Peak emission wavelength		
Decay time		
Thickness of phosphor (typ.)		
Base material of phosphor		
Spatial resolution *1	1 μm or less	800 nm or less
1st lens	10× (NA 0.45)	20× (NA 0.75)
2nd lens	200 mm	
ND filter	-	

\*1 Reference value with ORCA®-Flash4.0 V3. It varies depending on the system configuration.

### Light path

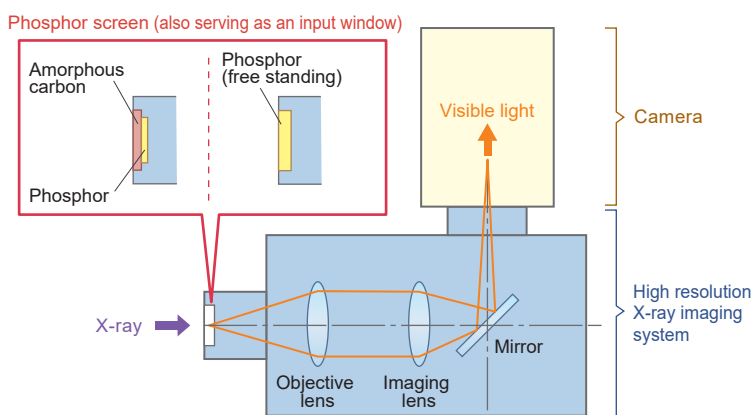

\* Phosphor screen is an option.  
\* For the components of the imaging optical system, brownning may be caused due to X-ray irradiation, resulting in a decrease in transmittance.

### Options

#### Phosphor specifications

Three types of phosphor screens are available: direct bonding type, glue bonding type, and free standing type. Among these, the direct bonding type has high X-ray durability and enables stable imaging even at high doses.

Bonding method	Product number	Phosphor material	Peak emission wavelength	Decay time	Phosphor thickness	Phosphor diameter	Phosphor effective diameter	Base material of phosphor	Space ring
Direct bonding <a href="#">See page 5</a>	A15150-LU010DB	LuAG *1 (Lu <sub>3</sub> Al <sub>5</sub> O <sub>12</sub> : Ce+)	535 nm	70 ns	10 μm	15 mm	10 mm	Amorphous carbon Diameter 20 mm Thickness 1 mm	Black plastic Outer diameter 20 mm Inner diameter 16 mm Thickness 2 mm
	A15150-LU050DB				50 μm				
	A15150-LU100DB				100 μm				
	A15150-GA010DB	GAGG *1 (Gd <sub>3</sub> Al <sub>2</sub> Ga <sub>3</sub> O <sub>12</sub> : Ce+)			10 μm				
	A15150-GA050DB				50 μm				
	A15150-GA100DB				100 μm				
Glue bonding	A15150-LU010GB	LuAG *1 (Lu <sub>3</sub> Al <sub>5</sub> O <sub>12</sub> : Ce+)	535 nm	70 ns	10 μm	15 mm	10 mm	Amorphous carbon Diameter 20 mm Thickness 1 mm	Black plastic Outer diameter 20 mm Inner diameter 16 mm Thickness 2 mm
	A15150-LU050GB				50 μm				
	A15150-LU100GB				100 μm				
	A15150-GA010GB	GAGG *1 (Gd <sub>3</sub> Al <sub>2</sub> Ga <sub>3</sub> O <sub>12</sub> : Ce+)			10 μm				
	A15150-GA050GB				50 μm				
	A15150-GA100GB				100 μm				
Free standing	A15141-LU	LuAG *1 (Lu <sub>3</sub> Al <sub>5</sub> O <sub>12</sub> : Ce+)	535 nm	70 ns	1000 μm	20 mm	16 mm	-	Black plastic Outer diameter 20 mm Inner diameter 16 mm Thickness 2 mm
	A15141-GA	GAGG *1 (Gd <sub>3</sub> Al <sub>2</sub> Ga <sub>3</sub> O <sub>12</sub> : Ce+)							

\*1 For LuAG and GAGG, a streak and white spots may occur. These are due to the characteristics of the single-crystal phosphor and are not a defect.

#### Optical components

Product number	Product name	Note
A15614-01	Objective lens 10× for AA51	Additional lens for M11427-58S or -58B
A15614-02	Objective lens 20× for AA51	Additional lens for M11427-57S or -57B
A15614-03	F-mount camera adapter for AA51	For F-mount camera

**Direct bonding phosphor**

## High-durability single-crystal phosphor screen revolutionizes conventional imaging



High-durability single-crystal phosphor screen (Direct bonding type)

The direct bonding type phosphor screen that can be selected as an option is a single-crystal phosphor screen with extremely high X-ray durability. It suppresses the destruction of a phosphor screen by X-rays and realizes stable imaging and measurement for a long period of time.

### X-ray durability evaluation ① Synchrotron radiation white X-ray

Conventional phosphor (Glue bonding type)

High-durability single-crystal phosphor screen (Direct bonding type)

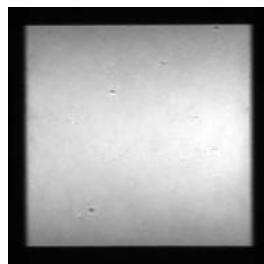

↓ Approx. 12 min. later (700 s.)

↓ 12 hours later

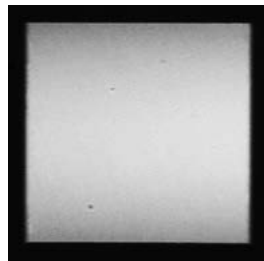
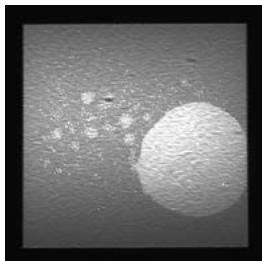

Destruction taking place

**No changes**

No destruction occurs even if synchrotron radiation white X-ray is incident for a long time.

#### Measurement conditions

Beam line	SPring-8 BL28B2
X-ray energy	White
Attenuator	Air (9 m), Aluminum (0.034 mm) Be window (1 mm thick on the beam line side + 0.5 mm thick on the detector side)
Beam size	3×3 mm <sup>2</sup>
Detector	Glue bonding type: AA40 (f = 50 mm) + ORCA®-Flash2.8 (f = 35 mm) Direct bonding type: AA40 (f = 50 mm) + ORCA®-Flash4.0 (f = 50 mm)
Pixel resolution	Glue bonding type: 5.1 μm / pixel, Direct bonding type: 6.5 μm / pixel
Scintillator	LuAG (Thickness: Glue bonding type about 20 μm, Direct bonding type about 20 μm) *

\* AA40 is used for durability evaluation. The single-crystal phosphor screen is not recommended for use with AA40.

#### Data courtesy

JASRI (Japan Synchrotron Radiation Research Institute)  
Industrial application Division  
Dr. Kentaro KAJIWARA

\* The measurement condition and data are at the time of evaluation and may not apply to all cases. Please consider as a reference case.

### X-ray durability evaluation ② Flux density $4.7 \times 10^{13}$ photons/s/mm<sup>2</sup>

Conventional phosphor (Glue bonding type)

High-durability single-crystal phosphor screen (Direct bonding type)

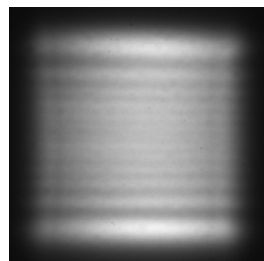
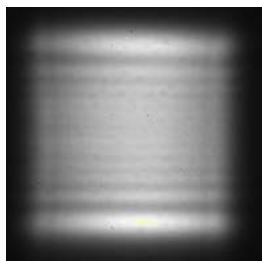

↓ 6 min. later

↓ Approx. 2 hours later (119 min.)

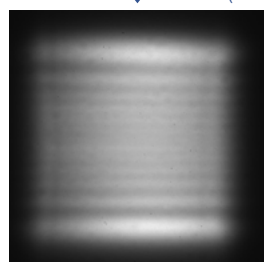
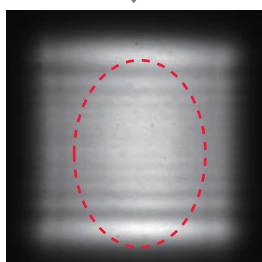

Destruction taking place

**No changes**

No destruction occurs even if X-rays with high flux density are incident over a long time about 20 times.

#### Measurement conditions

Beam line	SPring-8 BL47XU
X-ray energy	8 keV
Attenuator	None
Flux density	$4.7 \times 10^{13}$ photons/s/mm <sup>2</sup>
Beam size	350 × 350 μm <sup>2</sup>
Detector	AA50 (objective lens10×/NA 0.3) + C13949-50U
Pixel resolution	0.21 μm/pixel
Scintillator	LuAG (Thickness: Glue bonding type 22.3 μm, Direct bonding type 21.4 μm)

#### Data courtesy

JASRI (Japan Synchrotron Radiation Research Institute)  
Dr. Kentaro UESUGI

\* The measurement condition and data are at the time of evaluation and may not apply to all cases. Please consider as a reference case.

# Camera selection

## Camera specifications

Cameras to be combined can be selected from 5 models of Hamamatsu's scientific cameras in accordance with readout speed and readout noise.

For specifications and details other than those in the table below, please contact your Hamamatsu representative or distributor.

Camera	ORCA®-Quest qCMOS® camera		ORCA®-Fusion BT Digital CMOS camera		ORCA®-Fusion Digital CMOS camera		ORCA®-Flash4.0 V3 Digital CMOS camera	
Product number	C15550-20UP		C15440-20UP		C14440-20UP		C13440-20CU	
Effective number of pixels (H×V)	4096 × 2304		2304 × 2304		2304 × 2304		2048 × 2048	
Pixel size [ μm (H) × μm (V) ]	4.6 × 4.6		6.5 × 6.5		6.5 × 6.5		6.5 × 6.5	
Effective area [ μm (H) × μm (V) ]	18.841 × 10.598		14.976 × 14.976		14.976 × 14.976		13.312 × 13.312	
Full well capacity (electrons, typ.) *1	7000		15 000		15 000		30 000	
Readout speed (frames/s, typ.) *1	Standard scan	120	Fast scan	89.1	Fast scan	89.1	Standard scan	100
	Ultra quiet scan	5	Standard scan	23.2	Standard scan	23.2	Slow scan	30
	–	–	Ultra quiet scan	5.42	Ultra quiet scan	5.42	–	–
Readout noise (electrons, rms, typ.) *1	Standard scan	0.43	Fast scan	1.6	Fast scan	1.4	Standard scan	1.6
	Ultra quiet scan	0.27	Standard scan	1.0	Standard scan	1.0	Slow scan	1.4
	–	–	Ultra quiet scan	0.7	Ultra quiet scan	0.7	–	–

\*1 It varies depending on the conditions. Please contact Hamamatsu for details.

## Lens attachment

### Large area type

When using a large area type imaging unit, select a lens attachment compatible with the camera.

**M11427-43** (First lens focal distance: 50 mm)

Camera	Lens attachment	Second lens focal distance (mm)	Imaging magnification * (calculated amount)
ORCA®-Quest	A11444-8050	50	1.0
	A11444-8135A	135	2.7
ORCA®-Fusion BT ORCA®-Fusion	A11444-775	75	1.5
	A11444-7135A	135	2.7
ORCA®-Flash4.0 V3	A11444-4050	50	1.0
	A11444-4135A	135	2.7

\* Calculated value of second lens focal distance divided by first lens focal distance.

**M11427-62** (First lens focal distance: 75 mm)

Camera	Lens attachment	Second lens focal distance (mm)	Imaging magnification * (calculated amount)
ORCA®-Quest	A11444-8050	50	0.667
	A11444-8135A	135	1.8
ORCA®-Fusion BT ORCA®-Fusion	A11444-775	75	1.0
	A11444-7135A	135	1.8
ORCA®-Flash4.0 V3	A11444-4050	50	0.667
	A11444-4135A	135	1.8

\* Calculated value of second lens focal distance divided by first lens focal distance.

### Image after attachment



Lens attachment (A11444-4050) + ORCA®-Flash4.0 V3 (C13440-20CU)

# Other specifications

## System configuration examples

Frame grabber board and their cables are available with options depending on the camera used. For details, please contact your Hamamatsu representative or distributor.

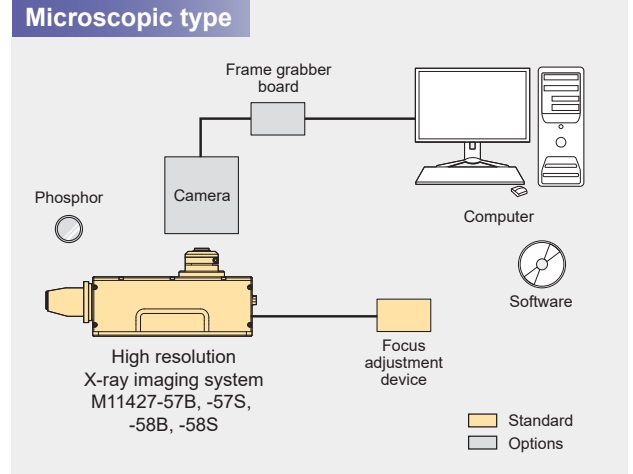
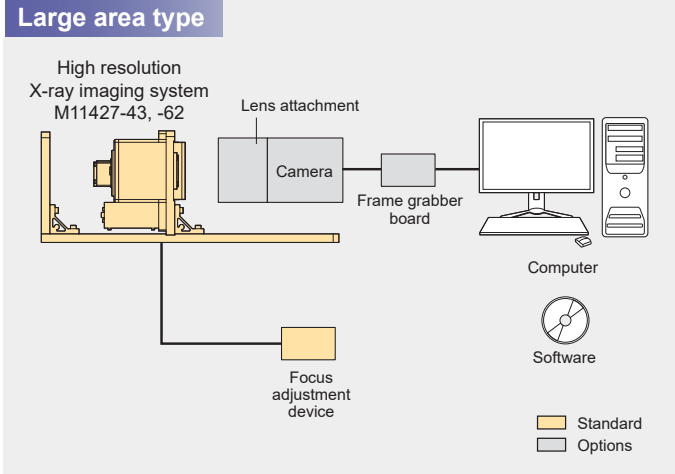

## Dimensional outlines (unit: mm)

- High resolution X-ray imaging system AA41 (50 mm) M11427-43 (Approx. 7.2 kg)

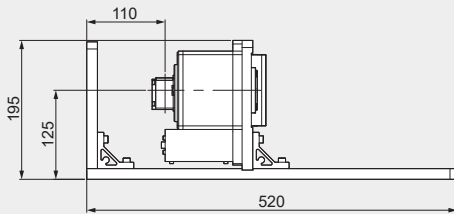

- High resolution X-ray imaging system AA60 M11427-62 (Approx. 6.5 kg)

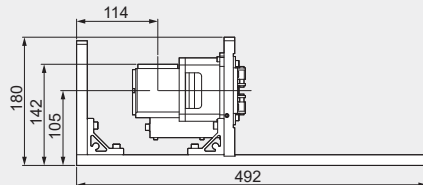

- High resolution X-ray imaging system AA51 M11427-57B, -57S, -58B, -58S (Approx. 7.5 kg)

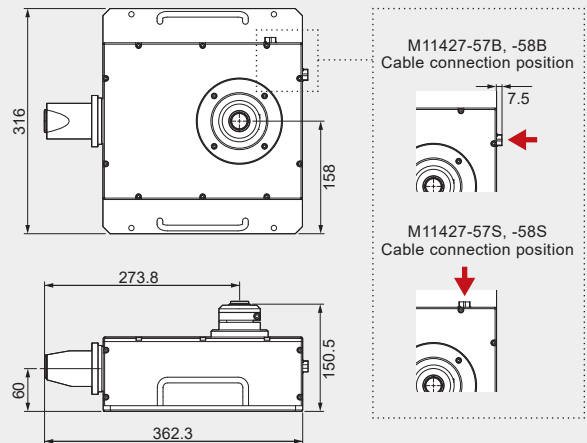

## Related products

---

### X-ray sCMOS cameras

These are X-ray image acquisition cameras that have an FOP (fiber optic plates) coupled to a CMOS sensor, on which an X-ray scintillator is applied.

By adopting the FOP, light can be efficiently transmitted from the phosphor to the sensor, consequently enabling high-sensitivity imaging.



#### X-ray sCMOS camera C12849-111U

A compact body is suitable for embedding in devices such as a micro X-ray CT.



#### ORCA®-Lightning X X-ray sCMOS camera C15606 series

It has an effective element size of 25.344 mm × 14.256 mm and 12 million pixels, enabling wide-field imaging.

- ORCA is a registered trademark of Hamamatsu Photonics K.K. (China, EU, France, Germany, Japan, UK, USA).
- qCMOS is a registered trademark of Hamamatsu Photonics K.K. (China, EU, Japan, UK, USA).
- The product and software package names noted in this brochure are trademarks or registered trademarks of their respective manufacturers.
- The products described in this brochure are designed to meet the written specifications, when used strictly in accordance with all instructions.
- The university, institute, or company name of the researchers, whose measurement data is published in this brochure, is subject to change.
- The measurement examples in this brochure are not guaranteed.
- Specifications and external appearance are subject to change without notice.

© 2023 Hamamatsu Photonics K.K.

---

## HAMAMATSU PHOTONICS K.K. [www.hamamatsu.com](http://www.hamamatsu.com)

### Systems Division

812 Joko-cho, Higashi-ku, Hamamatsu City, 431-3196, Japan, Telephone: (81)53-431-0124, Fax: (81)53-433-8031, E-mail: [export@sys.hpk.co.jp](mailto:export@sys.hpk.co.jp)

U.S.A.: HAMAMATSU CORPORATION: 360 Foothill Road, Bridgewater, NJ 08807, U.S.A., Telephone: (1)908-231-0960, Fax: (1)908-231-1218

Germany: HAMAMATSU PHOTONICS DEUTSCHLAND GMBH: Arzbergerstr. 10, 82211 Herrsching am Ammersee, Germany, Telephone: (49)8152-375-0, Fax: (49)8152-265-8 E-mail: [info@hamamatsu.de](mailto:info@hamamatsu.de)

France: HAMAMATSU PHOTONICS FRANCE S.A.R.L.: 19 Rue du Saule Trapu, Parc du Moulin de Massy, 91882 Massy Cedex, France, Telephone: (33)1 69 53 71 00, Fax: (33)1 69 53 71 10 E-mail: [infos@hamamatsu.fr](mailto:infos@hamamatsu.fr)

United Kingdom: HAMAMATSU PHOTONICS UK LIMITED: 2 Howard Court, 10 Tewin Road, Welwyn Garden City, Hertfordshire, AL7 1BW, UK, Telephone: (44)1707-294888, Fax: (44)1707-325777 E-mail: [info@hamamatsu.co.uk](mailto:info@hamamatsu.co.uk)

North Europe: HAMAMATSU PHOTONICS NORDEN AB: Torshamnsgatan 35 16440 Kista, Sweden, Telephone: (46)8-509 031 00, Fax: (46)8-509 031 01 E-mail: [info@hamamatsu.se](mailto:info@hamamatsu.se)

Italy: HAMAMATSU PHOTONICS ITALIA S.R.L.: Strada della Moia, 1 int. 6, 20044 Arese (Milano), Italy, Telephone: (39)02-93 58 17 33, Fax: (39)02-93 58 17 41 E-mail: [info@hamamatsu.it](mailto:info@hamamatsu.it)

China: HAMAMATSU PHOTONICS (CHINA) CO., LTD.: 1201 Tower B, Jiaming Center, 27 Dongsanhuan Beilu, Chaoyang District, 100020 Beijing, P.R. China, Telephone: (86)10-6586-6006, Fax: (86)10-6586-2866 E-mail: [hpc@hamamatsu.com.cn](mailto:hpc@hamamatsu.com.cn)

Taiwan: HAMAMATSU PHOTONICS TAIWAN CO., LTD.: 13F-1, No.101, Section 2, Gongdao 5th Road, East Dist., Hsinchu City, 300046, Taiwan(R.O.C), Telephone: (886)3-659-0080, Fax: (886)3-659-0081 E-mail: [info@hamamatsu.com.tw](mailto:info@hamamatsu.com.tw)

Cat. No. SCAS0011E25  
DEC/2023 HPK  
Created in Japan