

External quantum efficiency measurement system C9920-12



Luminous efficiency for light emitting devices is measured precisely by utilizing an integrating sphere

Light emitting materials are characterized by their fluorescence quantum yield. For light emitting devices like organic and inorganic LEDs the respective physical value is the external quantum efficiency, measured usually by electroluminescence (EL) method. For this application the External quantum efficiency measurement system C9920-12 system is designed.

The luminous efficiency of OLED devices depends on various factors such as absorption of the individual layers and of the glass substrate, reflectance of the surface, radiation angle and waveguiding capacity of the glass substrate. These effects are countered by using an integrating sphere as sample chamber.

The sample is placed inside the sphere and excited by constant current or voltage.

Employing a highly sensitive Hamamatsu CCD spectrometer as detector, the whole spectrum is measured instantaneously. The spectral data as well as the external quantum yield, I-V-L characteristics and further calculations are displayed by the dedicated software.

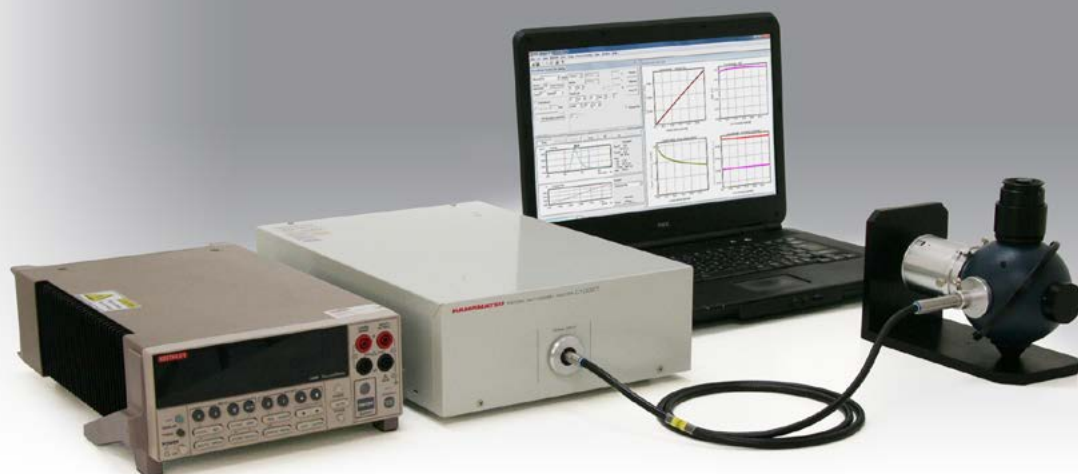

External quantum efficiency (EQE) measurement system utilizing an integrating sphere.

For measuring EQE of a light emitting device, it is placed inside an integrating sphere and excited by constant current. Current or voltage is changed stepwise and each time a complete emission spectrum is taken and displayed by the software.

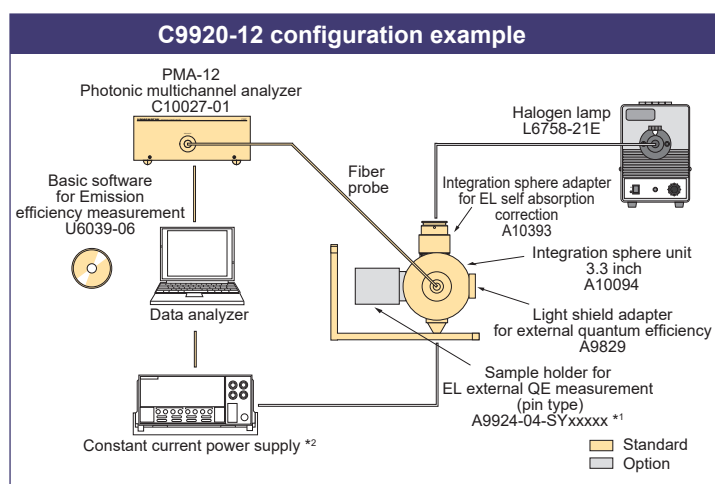

*1 This is a customized product for each customer.

*2 Please prepare Keythley Model 2400 Series or Model 2450 SourceMeter separately.

Features

- Use of an integrating sphere enables to measure EQE independent of the emission angle characteristic of a sample.
- Software controls the constant current power supply.
- The spectrum for each step of the applied voltage/current is measured instantaneously (I-V-L measurement).
- Cooled BT-CCD enables high sensitive measurement.
- Easy to handle intuitive software for measuring, calculating and controlling the system.
- Display of combination of several variables (current, voltage, luminous efficiency, chromaticity, etc).
- The system can be easily extended to absolute PL quantum yield measurement system and light distribution measurement system.

Specifications

Integrating sphere	3.3 inch inside diameter, reflective material: Spectralon
Detector	BT-CCD
Device Cooling temperature	-15 °C
Number of photosensitive device channels	1024 ch
Wavelength measurement range	200 nm to 950 nm (for spectrum display range) 380 nm to 780 nm (for color measurement and luminous flux calculation range)
Fiber length	1.5 m
Range of measurement for luminous flux	0.000 13 lm to 0.12 lm (with an emission area 2 mm square and white light)

Simple and intuitive handling is realized through the dedicated analysis software.

Software windows

Set up

- Minimum current
- Minimum voltage
- Maximum current
- Maximum voltage
- Step current
- Step voltage etc.

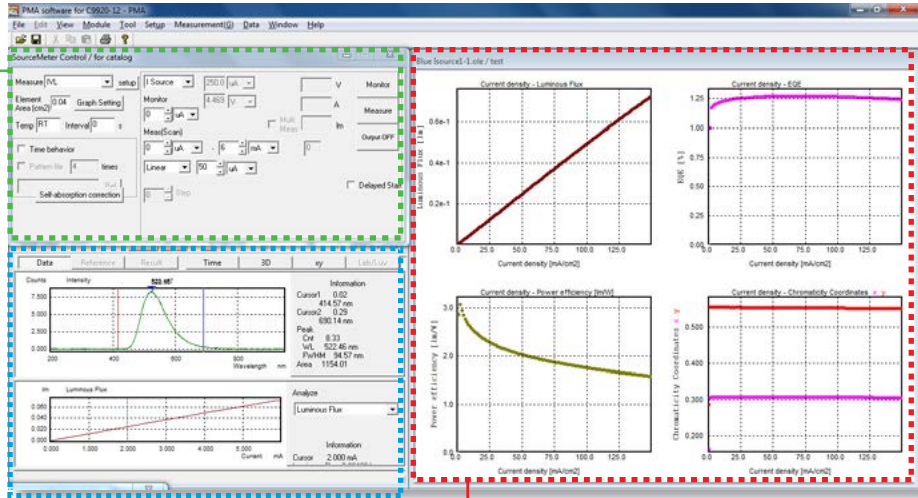

Measurement data

Results

- Current density/EQE
- Current density/Luminous efficiency (cd/A)
- Current density/Power efficiency
- Current density/Voltage
- Current density/Dominant wavelength
- Current density/Chromaticity coordinates
- Current density/Excitation purity
- Current/External differential quantum efficiency
- Time/Current (voltage)
- Time/Emission spectrum
- Wavelength/Intensity

Example of measurement results

Measurement results can be displayed in various graphic representations.

Current density/Voltage

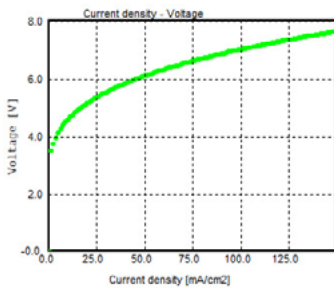

Current density/Chromaticity coordinates

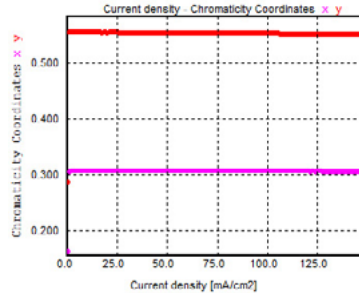

Current density/Dominant wavelength

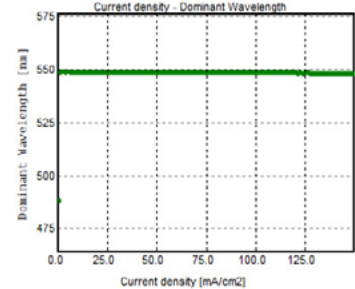

Current density/Luminous flux

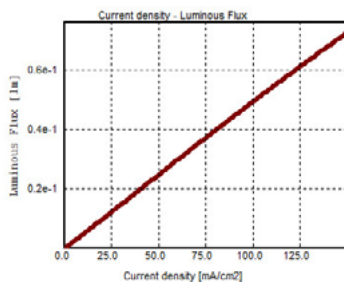

Current density/Power efficiency

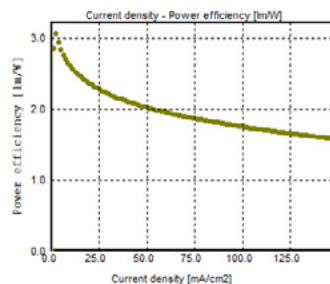

Wavelength/Intensity

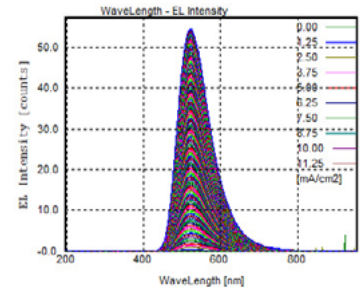

* The Voltage parameter is alternatives for Current Density.

Addition of optional parts and components accommodates a wide variety of measurement objects.

Options



Halogen lamp L6758-21E

This lamp is necessary for absorption correction of your sample.



Integration sphere adapter for EL self absorption correction A10393

Adapter to joint an integrating sphere and a fiber of light source for absorption correction. (for L6758-21)



Sample holder for EL external QE measurement (pin type) A9924-04-SYxxxxx *

A sample holder with pin connectors. This is a customized product for your sample. * xxxxx would be unique numbers for each product.

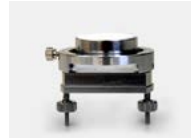

Sample holder for EL external QE measurement (simple type) A9924-06

A general-purpose sample holder with alligator clips. It comes with a light shielding cover.

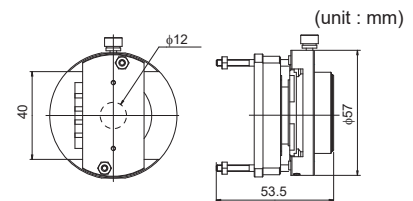

Related Products

With many shared components, the C9920 series offers easy upgrades to the following products.

● Absolute PL quantum yield spectrometer C9920-02, -02G, -03, -03G

These systems measure the absolute values of luminous quantum yields of light-emitting materials using the photoluminescence method.

Absolute PL quantum yield measurement systems C9920-02, -02G, -03, and -03G measure the absolute values of luminous quantum yields of light-emitting materials using the photoluminescence method. Use of a spectrometer enables excitation at a variety of wavelengths. We have various sample holders that can accommodate measurement of thin films as well as solutions and powders.

● Light distribution measurement system C9920-11

This system integrates a rotating stage to measure the brightness, emission spectrum, chromaticity coordinates, and other elements for each emission angle.

The C9920-11 luminous intensity distribution characteristic measurement system measures the emission brightness, spectrum, and emission angle distribution of a light-emitting device for every preconfigured step angle by placing the light-emitting device supplied with electric current (or voltage) on the rotating stage.

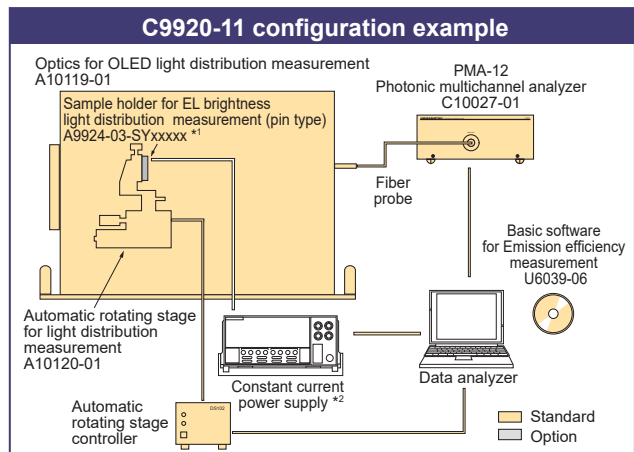
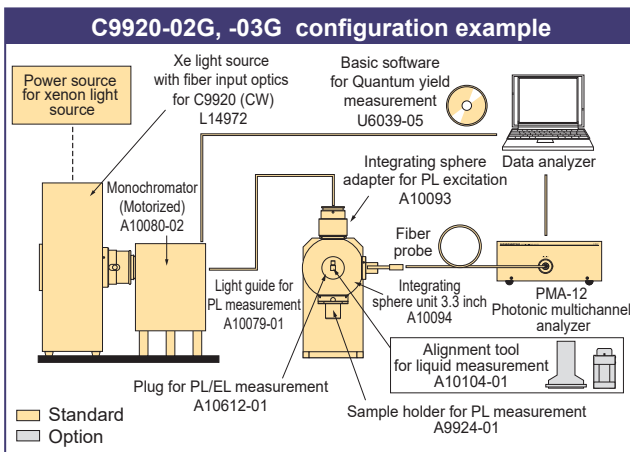

*1 This is a customized product for each customer.

*2 Please prepare Keithley Model 2400 Series or Model 2450 SourceMeter separately.

- The product and software package names noted in this brochure are trademarks or registered trademarks of their respective manufactures.
- Subject to local technical requirements and regulations, availability of products included in this brochure may vary. Please consult your local sales representative.
- The products described in this brochure are designed to meet the written specifications, when used strictly in accordance with all instructions.
- Specifications and external appearance are subject to change without notice.

© 2022 Hamamatsu Photonics K.K.

HAMAMATSU PHOTONICS K.K. www.hamamatsu.com

Systems Division

812 Joko-cho, Higashi-ku, Hamamatsu City, 431-3196, Japan, Telephone: (81)53-431-0124, Fax: (81)53-433-8031, E-mail: export@sys.hpk.co.jp

U.S.A.: HAMAMATSU CORPORATION: 360 Foothill Road, Bridgewater, NJ 08807, U.S.A., Telephone: (1)908-231-0960, Fax: (1)908-231-1218

Germany: HAMAMATSU PHOTONICS DEUTSCHLAND GMBH.: Arzbergerstr. 10, 82211 Herrsching am Ammersee, Germany, Telephone: (49)8152-375-0, Fax: (49)8152-265-8 E-mail: info@hamamatsu.de

France: HAMAMATSU PHOTONICS FRANCE S.A.R.L.: 19 Rue du Saule Trapu, Parc du Moulin de Massy, 91882 Massy Cedex, France, Telephone: (33)1 69 53 71 00, Fax: (33)1 69 53 71 10 E-mail: infos@hamamatsu.fr

United Kingdom: HAMAMATSU PHOTONICS UK LIMITED: 2 Howard Court, 10 Tewin Road, Welwyn Garden City, Hertfordshire, AL7 1BW, UK, Telephone: (44)1707-294888, Fax: (44)1707-325777 E-mail: info@hamamatsu.co.uk

North Europe: HAMAMATSU PHOTONICS NORDEN AB: Torshamnsgatan 35 16440 Kista, Sweden, Telephone: (46)8-509 031 00, Fax: (46)8-509 031 01 E-mail: info@hamamatsu.se

Italy: HAMAMATSU PHOTONICS ITALIA S.R.L.: Strada della Moia, 1 int. 6, 20044 Arese (Milano), Italy, Telephone: (39)02-93 58 17 33, Fax: (39)02-93 58 17 41 E-mail: info@hamamatsu.it

China: HAMAMATSU PHOTONICS (CHINA) CO., LTD.: 1201 Tower B, Jianning Center, 27 Dongsanhuan Beilu, Chaoyang District, 100020 Beijing, P.R. China, Telephone: (86)10-6586-6006, Fax: (86)10-6586-2866 E-mail: hpc@hamamatsu.com.cn

Taiwan: HAMAMATSU PHOTONICS TAIWAN CO., LTD.: 8F-3, No.158, Section 2, Gongdao 5th Road, East District, Hsinchu, 300, Taiwan R.O.C., Telephone: (886)3-659-0080, Fax: (886)3-659-0081 E-mail: info@hamamatsu.com.tw

Cat. No. SSMS0018E07
DEC/2022 HPK
Created in Japan