

Mini-spectrometers

1. Overview

Spectrophotometers for color measurement, chemical analysis, etc. are usually large devices so samples for measurement had to be brought into a chemical lab, etc. where these bulky devices are installed. This has led to rapidly mounting interest in recent years in devices capable of making on-site analysis by real-time measurements without having to bring samples into a special lab as well as monitoring measurements during constant observation.

By merging image sensor technology accumulated over long years with MEMS technology such as etching, Hamamatsu succeeded in developing mini-spectrometer products that offer compact size along with low cost. These mini-spectrometers contain an optical system such as a grating (wavelength dispersing component) and a linear image sensor. Mini-spectrometers can be used in a wide range of measurement fields including chemical analysis, color measurement, environmental measurement, and process control in production lines. Hamamatsu also provides ultra-compact models specifically designed for assembly into portable measuring devices.

2. Configuration

Monochromators are widely used spectrometric equipment. Monochromators usually have an exit slit arranged along the focal plane of the focusing lens (or focusing mirror). Polychromators operate on the same principle as monochromators but are designed to allow simultaneous detection of multiple spectra. Mini-spectrometers are compact polychromators in which a linear image sensor is arranged on the focal plane of the focusing lens/mirror. To make mini-spectrometers compact and portable, the focal lengths of the collimating lens/mirror and focusing lens/mirror are made shorter than in monochromators.

Functions of major components used in mini-spectrometers are described below.

Entrance slit

This is an aperture through which the light to be measured is guided. Aperture size has significant effects on optical characteristics such as spectral resolution and throughput. There are two light input methods: optical fiber input and spatial light input.

Collimating lens/mirror

The light passing through the entrance slit spreads at a certain angle. The collimating lens collimates this slit-transmitted light and guides it onto the grating.

Grating

The grating separates the incident light guided through the collimating lens into different wavelengths and lets the light at each wavelength pass through or reflect away at a different diffraction angle.

Focusing lens/mirror

The focusing lens or mirror forms an image of the light dispersed into wavelengths by the grating onto the linearly arranged pixels of the image sensor according to wavelength.

Image sensor

The image sensor converts the optical signals, which were dispersed into wavelengths by the grating and focused by the focusing lens, into electrical signals and then outputs them.

[Figure 2-1] Optical system layout (TG series)

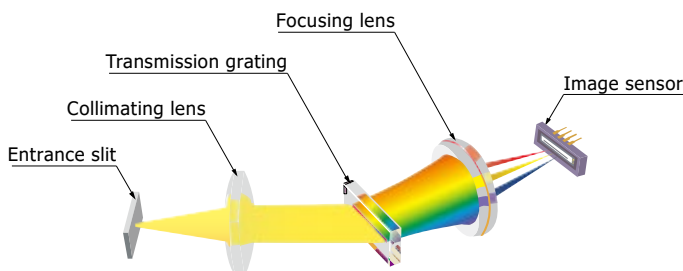

KACCC0256EA

2-1. Entrance slit

(1) Slit width

The entrance slit limits the spatial spread of the measurement light entering the mini-spectrometer. The slit image is focused onto the image sensor in the mini-spectrometer. The slit width is an essential factor in determining spectral resolution. The narrower the slit width, the more the spectral resolution of the mini-spectrometer is improved. However, since the optical system has aberrations, there is a limit to how much the spectral resolution can be improved. Effects from optical system aberrations can be reduced by making the NA (numerical aperture) smaller. This somewhat extends the limit on improving the spectral resolution.

Spectral resolution and throughput have a mutual trade-off. For example, narrowing the slit width or making the NA smaller reduces the equipment throughput. The slit width and NA must be found by taking the required spectral resolution and throughput into account.

[Table 2-1] NA/slit width of mini-spectrometers (C10082CA/C10083CA series)

Type no.		NA	Slit width
Spectral response range 200 to 800 nm	Spectral response range 320 to 1000 nm		
C10082CA-2200	C10083CA-2200	0.22	200 μm
C10082CA-2100	C10083CA-2100		100 μm
C10082CA	C10083CA		70 μm
C10082CA-2050	C10083CA-2050		50 μm
C10082CA-1050	C10083CA-1050		50 μm
C10082CA-1025	C10083CA-1025	0.11	25 μm
C10082CAH	C10083CAH		10 μm

[Figure 2-2] Spectral resolution vs. wavelength
(a) C10082CA series

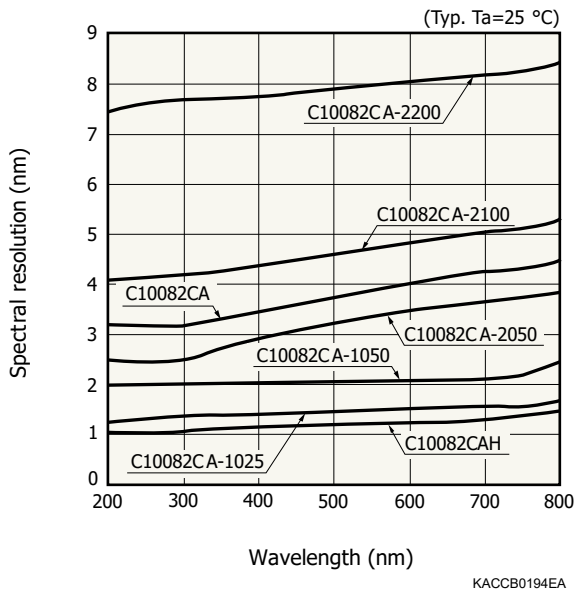

(b) C10083CA series

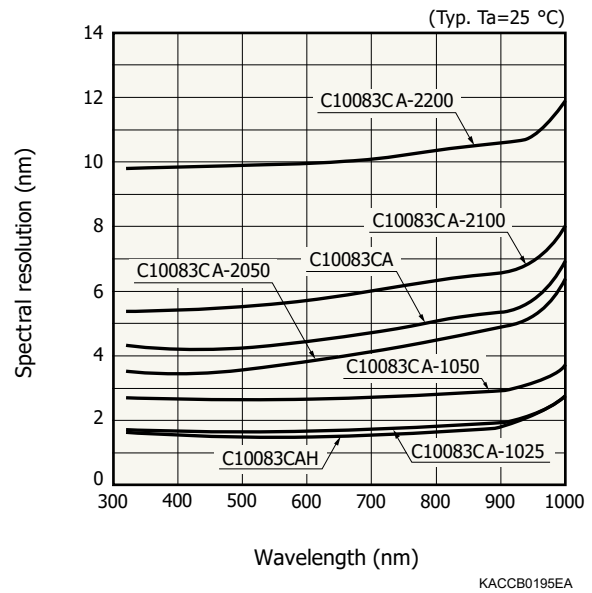

(2) Slit height

The slit height affects the equipment throughput but has almost no effect on spectral resolution. In actual operation, however, the slit image focused on the image sensor becomes distorted due to optical system aberrations. This distortion may impair the spectral resolution and stray light characteristics so use caution.

Center wavelength of spectral line

To determine the center wavelength (λ_c) of a spectral line, the spectral line should be detected by 3 or more pixels and approximated by a Gaussian function.

[Figure 2-3] Determining the center wavelength of a spectral line by Gaussian function approximation

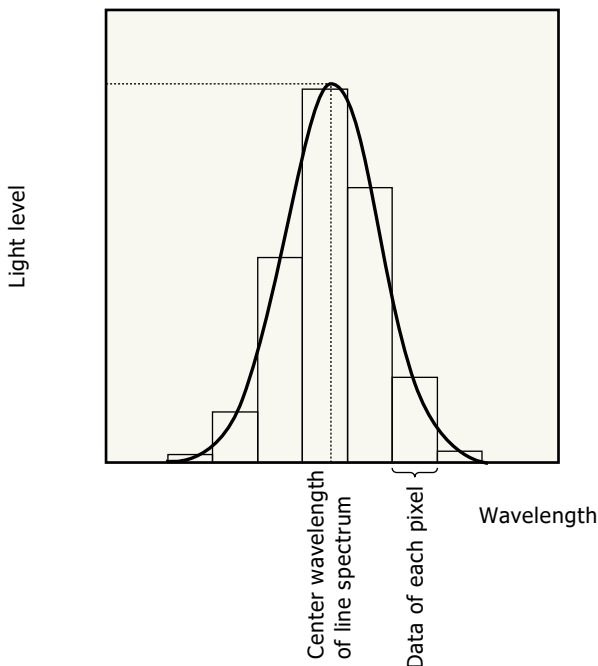

KACCC0335EA

2-2. Collimating lens (mirror)

The collimating lens collimates slit-transmitted light and guides it onto the grating. An aperture is used along with the collimating lens to limit the NA (numerical aperture) ^{*1} of a light flux.

*1: The NA of a light flux can be found from the solid angle.

e.g. If the solid angle (θ) of a light flux is 25.4° then NA is given as follows:

$$NA = \sin \frac{\theta}{2} \approx 0.22$$

2-3. Grating

(1) Diffraction grating equation

The principle by which a diffraction grating separates light into different wavelengths can be expressed by the diffraction grating equation (2-1).

$$d (\sin \alpha \pm \sin \beta) = m\lambda \dots\dots\dots (2-1)$$

d: aperture distance

α : incident angle (angle formed by incident light and grating normal line)

β : diffraction angle (angle formed by diffracted light and grating normal line)

m: order of diffraction ($m= 0, \pm 1, \pm 2 \dots$)

λ : wavelength

[Figure 2-4] Variables in diffraction grating equation

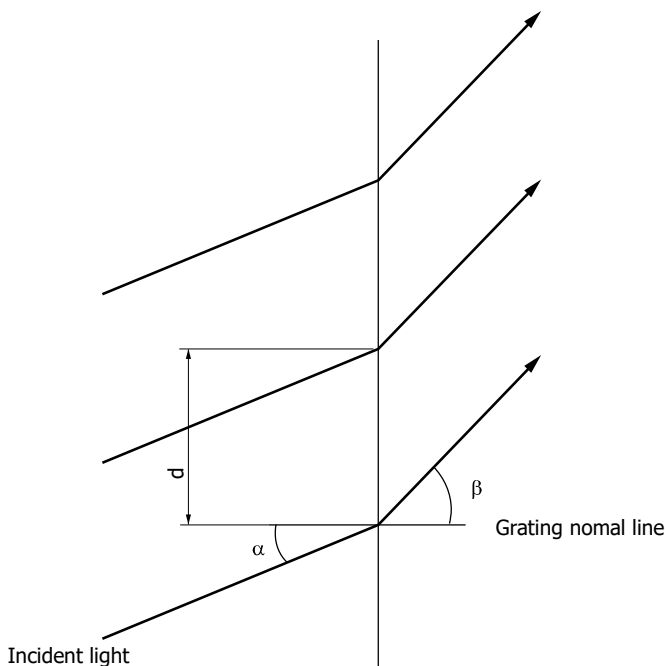

KACCC0246EC

(2) Specifications

Major specifications of a grating include the following four factors:

- Size
- Lattice frequency: number of slits (grooves) per 1 mm
- Effective diffraction wavelength band (blazed wavelengths)
- Diffraction efficiency

Lattice frequency

The lattice frequency (N) is expressed by equation (2-2).

$$N = 1/d \dots\dots\dots (2-2)$$

d: aperture interval

The lattice frequency is a parameter that determines reciprocal dispersion (D). Reciprocal dispersion indicates a wavelength difference per unit length on the focal plane of a focus lens. Reciprocal dispersion is given as follows:

From the diffraction grating equation $d (\sin \alpha \pm \sin \beta) = m\lambda$
 $\sin \alpha \pm \sin \beta = Nm\lambda$

Differentiating both sides by λ while keeping the incident angle α constant gives:

$$d\beta/d\lambda = Nm/\cos\beta$$

Multiplying both sides by the focal distance (f) of the focus lens gives:

$$f \cdot d\beta/d\lambda = Nm f/\cos\beta$$

The reciprocal of this is a reciprocal dispersion and, if $f \cdot d\beta = dx$, then we obtain:

$$D = d\lambda/dx = \cos\beta/Nmf$$

Diffraction efficiency

Diffraction efficiency (DE) is a value expressing the extent to which energy can be extracted as diffracted light from incident light energy. The diffraction efficiency of mini-spectrometers is expressed as the ratio of the diffracted light level of a given order to the incident light level. Hamamatsu transmission gratings have a lattice shape that ensures a constant diffraction efficiency over a wide spectral range. On the other hand, Hamamatsu reflection gratings are blazed gratings (sawtooth pattern) that offer high diffraction efficiency at particular wavelengths.

Hamamatsu mini-spectrometers contain either of the gratings shown in Table 2-2. The gratings used in these mini-spectrometers were designed using our advanced optical simulation technology to have an optimal convexo-concave ratio and groove depth so that they can offer a diffraction efficiency and polarization dependence ideal for each product.

[Table 2-2] Gratings used in mini-spectrometers

Type	Master/ Replica	Manufacturing method	Material	Shape	Features
Transmission type	Master	Etching	Quartz	Lattice	<ul style="list-style-type: none"> • Stable against temperature variations • Constant diffraction efficiency over a wide spectral range • Lower exit angle dependence of diffraction light on grating angle • Lattice frequency can be increased.
Reflection type	Replica	Molding	Resin	Blazed (sawtooth pattern)	<ul style="list-style-type: none"> • Low cost • High diffraction efficiency at particular wavelengths

[Figure 2-5] Diffraction efficiency (typical example)
 (a) C11482GA, C9913GC

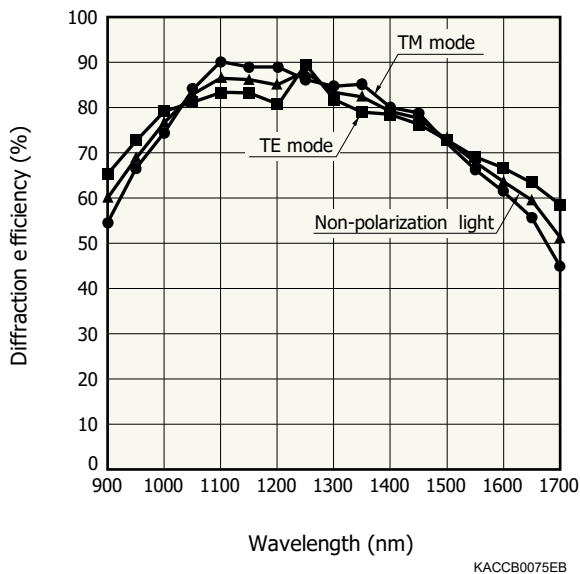

(b) C9914GB

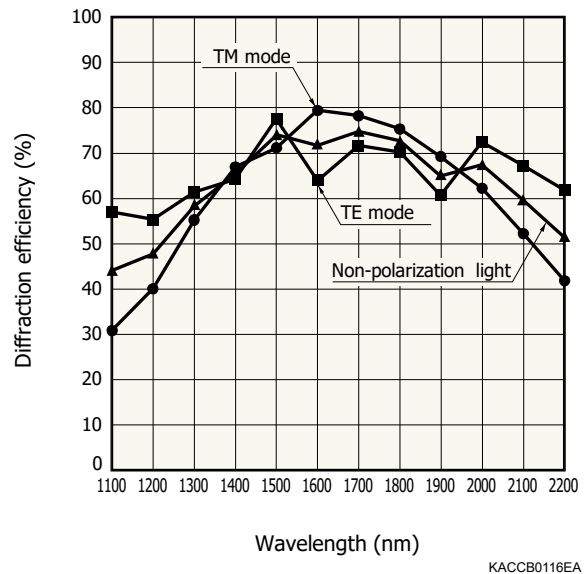

2-4. Focusing lens (mirror)

The focusing lens linearly focuses the diffracted light from the grating onto the image sensor according to wavelength.

2-5. Image sensor

Hamamatsu mini-spectrometers incorporate an image sensor optimized based on long-accumulated image sensor technology.

The spectrum formed by the grating is linearly focused by the focusing lens (mirror) onto the image sensor at each wavelength, and is photoelectrically converted into an electrical signal. The image sensor outputs the signal of light incident on each pixel at a certain time interval. This time interval is called the integration time. The light signal output can be optimized by adjusting the integration time. In low-light-level detection, for example, lengthening the integration time allows increasing the light signal output to a level where the signal can be processed.

(1) Time-series integration method and simultaneous integration method

Charge integration methods for image sensors used in mini-spectrometers are either the time-series integration method or the simultaneous integration method.

Time-series integration method

In image sensors using the time-series integration method, the signal is transferred while switching the address. Sequential pulses from the shift register are applied to the photodiode array as an address signal and the charge accumulated in each photodiode is output to the common signal line.

As shown in the timing chart (Figure 2-6), the integration time of each pixel is the same but the scan timing differs from pixel to pixel, so caution is required when the incident light to be detected varies over time. To detect pulsed light, the pulsed light should preferably be input while all pixels are integrating.

In this time-series integration method, the cycle time (T_c) equals the integration time (T_s).

If the readout time at each pixel is $4 \mu\text{s}/\text{ch}$ and the number of pixels is 512 ch, then the total readout time (T_r) of the sensor is expressed as follows:

$$T_r = 4 \mu\text{s}/\text{ch} \times 512 \text{ ch} = 2.048 \text{ ms}$$

[Figure 2-6] Timing chart (time-series integration method)

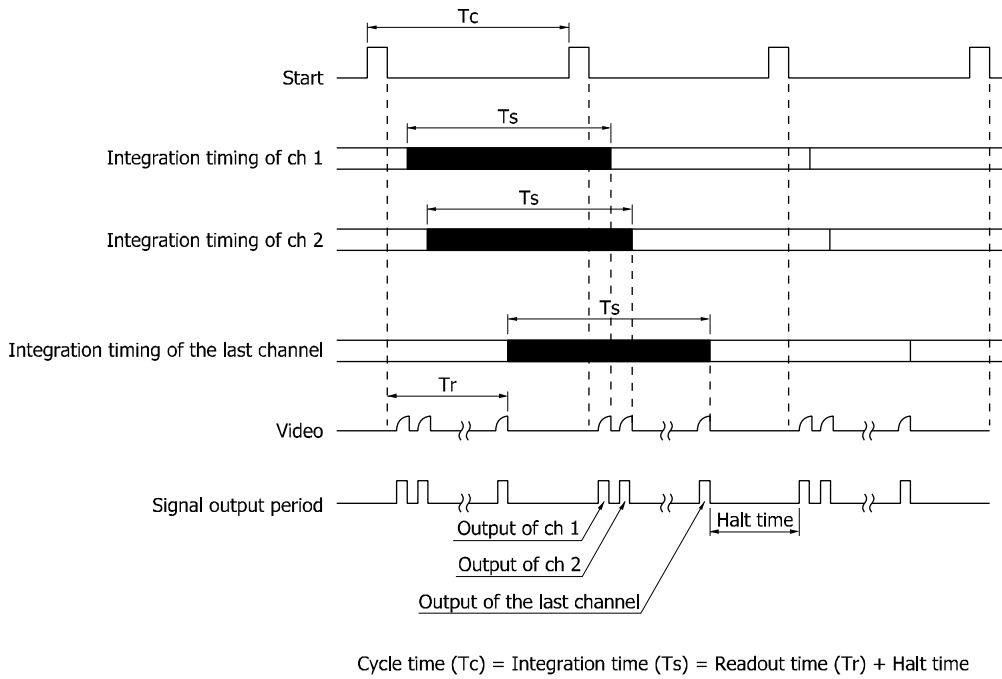

KACCC0247EA

[Figure 2-7] Difference between time-series integration and simultaneous integration methods

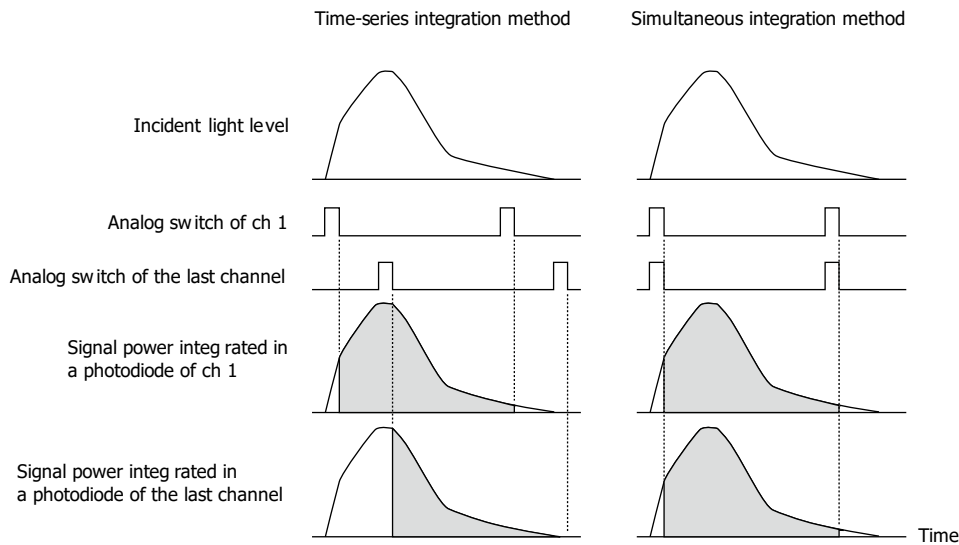

KACCC0250EA

Simultaneous integration method

In image sensors using the simultaneous integration method, when pulses are input from the shift registers, the charges accumulated in the photodiodes are transported to the analog shift registers from all pixels at the same time. Each pixel charge is sequentially transferred and output to the output section by a clock pulse. This method is used by Hamamatsu high-sensitivity CMOS linear image sensors and InGaAs linear image sensors. The integration time (T_s) of high-sensitivity CMOS linear image sensors is controlled by the ST signal level, while that of InGaAs linear image sensors is controlled by the RESET signal level. The charges are integrated in synchronization with the high level of the ST or RESET signal. The cycle time (T_c) will be the sum of the integration time (T_s) and the reset period (T_{reset}). Note that light signals that enter during the reset period are not detected. Pulsed light must be input within the integration time in order to be detected.

[Figure 2-8] Timing chart (simultaneous integration method)

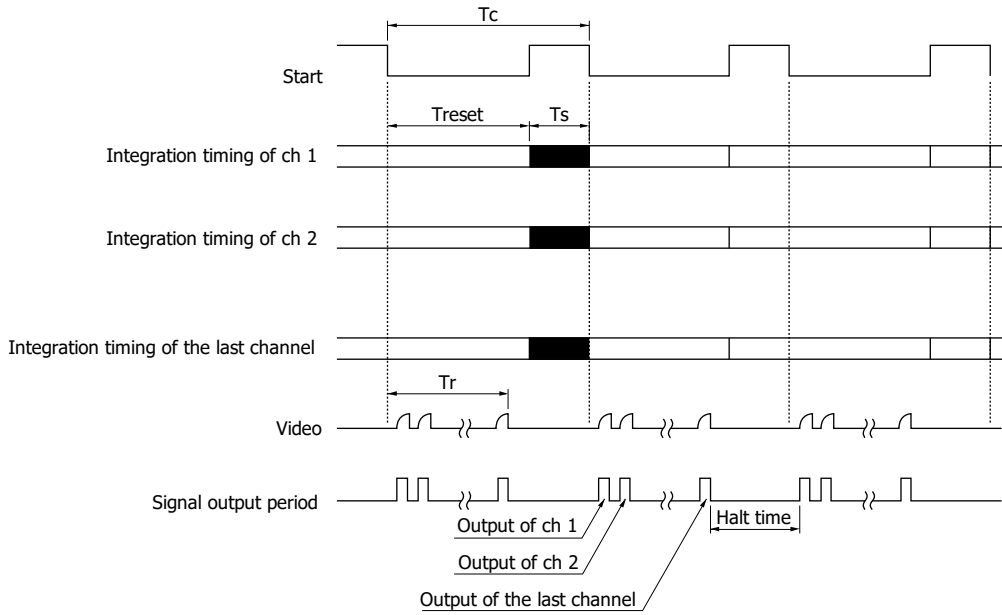

$$\text{Cycle time } (T_c) = \text{Integration time } (T_s) + \text{Reset period } (T_{\text{reset}})$$

KACCC0248EA

(2) Comparison among mini-spectrometers using the same optical system

The C10083CA, C10083MD and C11697MB of the TM series mini-spectrometers use different image sensors with the same optical system. Each has the following features.

[Table 2-3] Comparison among mini-spectrometers using the same optical system

Parameter	C10083CA	C10083MD	C11697MB
Sensitivity	Very high	Low	Very high
Linearity	Very high	Very high	High
Dark output	Low	Very low	Not so low
Noise	Low	Very low	Not so low
Shutter function	No	No	Yes
Power	USB bus power and AC adapter	USB bus power	USB bus power

[Figure 2-9] Spectral response (typical example)

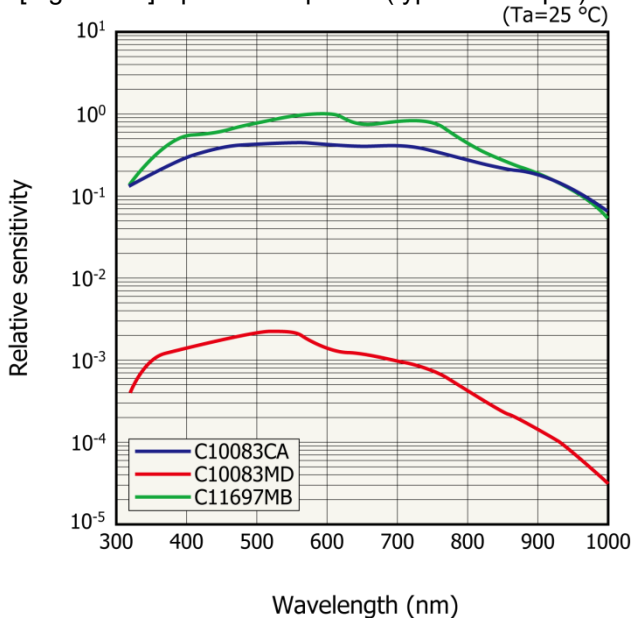

KACCB0406EA

[Figure 2-10] Dark output vs. integration time (typical example)

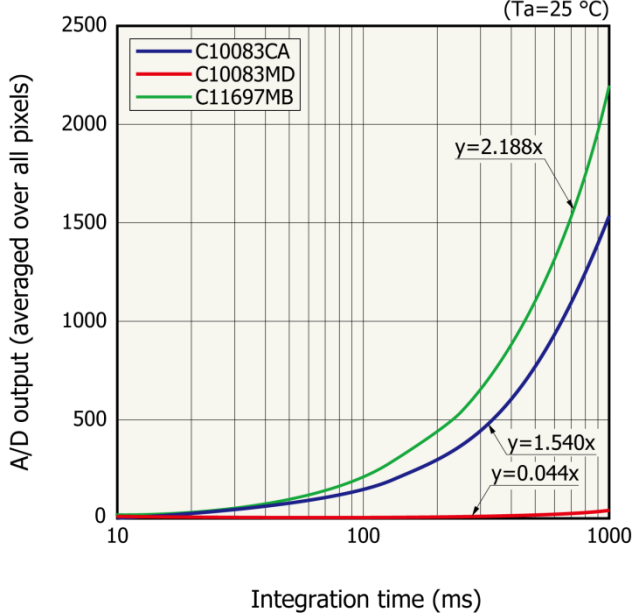

The A/D output is the sum of the sensor and circuit offset outputs and the sensor dark output. The equations in the graph are approximation formulas for the dark output of each product.

KACCB0407EA

[Figure 2-11] Spectral resolution vs. wavelength (typical examples)

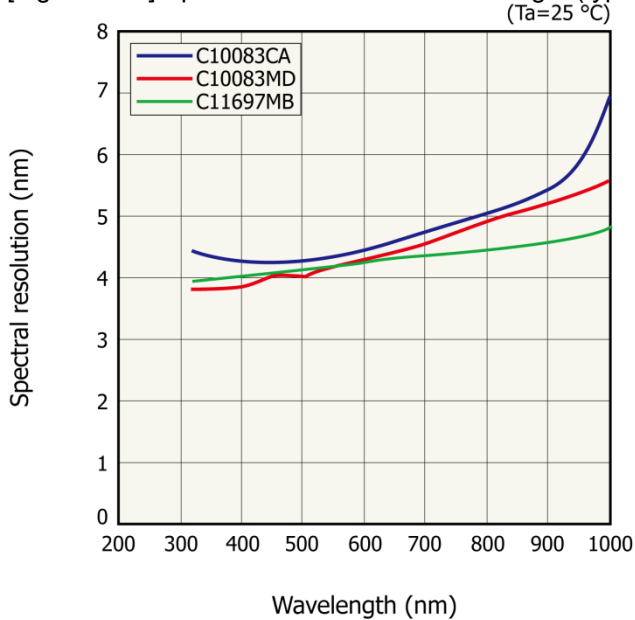

KACCB0408EA

[Figure 2-12] Linearity (typical example)

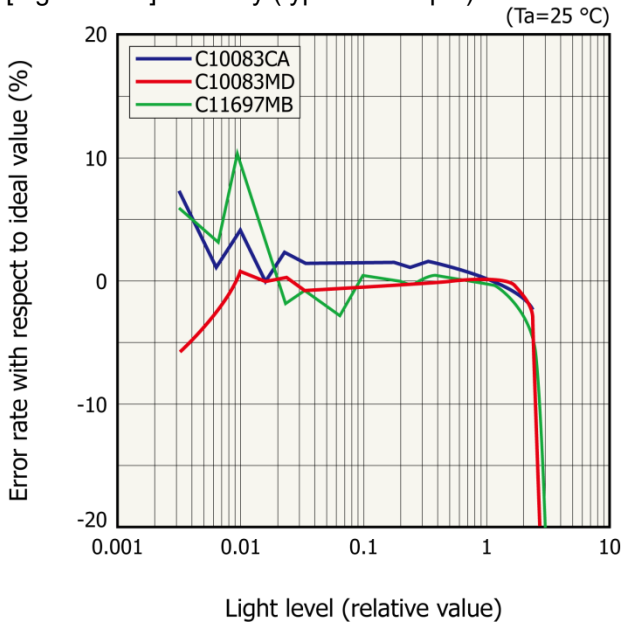

Ideally, the A/D output of mini-spectrometers should be proportional to the incident light level. The ideal value in this graph is specified by a straight line connecting the origin point to the point at which the A/D output is nearly one-half of the saturation level. This graph shows the differences between the actual output and the ideal value, in terms of percentage to the ideal value. The horizontal axis is the relative value to the light level (set as 1) at which the A/D output is nearly one-half of the saturation level.

KACCB0409EA

2-6 Guiding light to a mini-spectrometer

Mini-spectrometers are available with two different light input methods.

- Optical fiber input type with SMA905 connector:
Guides measurement light to the mini-spectrometer by connecting to an SMA905 connector optical fiber.
- Spatial input type:
Guides measurement light to the mini-spectrometer without using an optical fiber.

This section describes the optical fibers used to guide light and the light input methods.

Effects from bending the optical fiber

An optical fiber cable (patch cord) consists of an optical fiber (core), a protective tube for protecting the optical fiber, and an optical fiber connector attached to both ends of the optical fiber. The core of the optical fiber is surrounded by a cladding having a refractive index slightly lower than that of the core. Light striking the core-to-cladding interface at an angle greater than the critical angle is totally reflected due to the difference in the refractive index between the core and the cladding, and so is transmitted through the optical fiber. The angle at which light enters the optical fiber is the NA (numerical aperture) of the optical fiber.

[Figure 2-13] Light entering an optical fiber

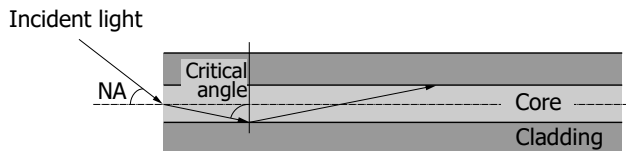

KACCC0656EA

The light transmission state in the optical fiber changes when bent. Be aware that the mini-spectrometer output may vary if the optical fiber connected to the mini-spectrometer is bent or swung during measurement.

Note: Bending the optical fiber more than the minimum bend radius specified in "Mini-spectrometers selection guide (page 17)" may break the optical fiber and must be avoided.

Making the NA (numerical aperture) of the incident light equal to or greater than 0.22

The optical system used in most of mini-spectrometers is designed to be NA=0.22. So the portion where measurement light is incident on the mini-spectrometer must be NA≥0.22. The light input methods satisfying this condition are described below.

(1) Making the optical fiber end sufficiently close to the measurement sample

In this case, the NA of the light emitted from the measurement sample must be sufficiently larger than 0.22.

a. Measuring a sample with a finite size of the light-emitting area

[Figure 2-14] Measurement sample and optical fiber arrangement example (1)

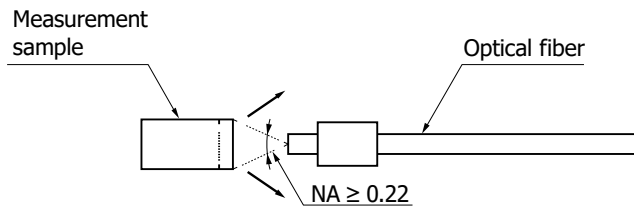

Make a setup so that the angle at which the measurement sample's emitting light viewed from the optical fiber is NA≥0.22. (Check the size and NA of the measurement sample's light-emitting area and the distance between the measurement sample and the optical fiber.)

KACCC0654EB

Since the solid angle is 25.4 degrees when NA=0.22, the distance L from the measurement sample to the input end of the optical fiber must meet the following conditions:

$$D/2 \geq \tan \{(25.4^\circ/2) \times L\} + d/2$$

$$L \leq (D/2 - d/2) / \tan(25.4^\circ/2) = (D - d)/0.45$$

Measurement sample diameter: D

Optical diameter core diameter: d

b. Measuring a point light source sample

[Figure 2-15] Measurement sample and optical fiber arrangement example (2)

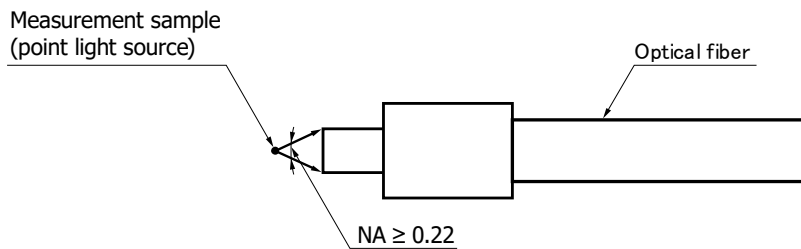

Set the distance between the measurement sample and the input end of the optical fiber so that the angle at which the optical fiber core diameter is viewed from the measurement sample (point light source) is NA≥0.22.

KACCC0768EA

The distance L must meet the following conditions:

$$\tan(25.4^\circ/2) \geq (d/2)/L$$

$$L \leq (d/2) / \tan(25.4^\circ/2) = d/0.45$$

(2) Using a condenser lens to let light enter the optical fiber under the conditions of NA≥0.22

a. Measuring a sample with a finite size of the light-emitting area or a point light source sample

[Figure 2-16] Measurement sample and optical fiber arrangement example (3)

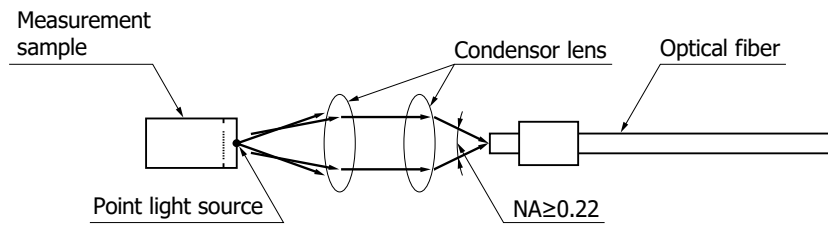

KACCC0655EB

Select the aperture and focal length of the condenser lens so that the angle at which the output light from the condenser lens facing the optical fiber viewed from the optical fiber is $NA \geq 0.22$.

The aperture d and focal length f of the condenser lens must meet the following conditions:

$$\tan(25.4^\circ/2) \leq (d/2)/f$$

$$d \geq 2 \times f \times \tan(25.4^\circ/2) = f \times 0.451$$

In actual measurement, the light flux emitted from the measurement sample may have directivity and/or an intensity distribution on a plane, so use caution. Also, when using an optical component to condense light, its aberration must be taken into account.

Optical fibers that connect to mini-spectrometers must meet the following conditions.

- (1) The optical fiber should have high transmittance in the spectral response range of the mini-spectrometer to be used and the spectral range of light for measurement.

Pure quartz optical fibers generally exhibit high transmittance over a wide spectral range. However, pure quartz optical fibers containing a large quantity of hydroxyl group have high transmission loss in longer wavelength ranges (for example near $1 \mu\text{m}$). On the other hand, pure quartz optical fibers containing a small quantity of hydroxyl group and Ge-doped quartz optical fibers exhibit small transmission loss in the longer wavelength range but have large transmission loss in the ultraviolet range. In the ultraviolet region near 250 nm, deterioration can occur even in quartz optical fibers. Carefully select the optical fiber by taking these facts into account.

[Figure 2-17] Transmission loss of optical fibers (typical examples)

(a) Pure quartz fiber (resistant to UV light)

(b) Ge-doped quartz fiber

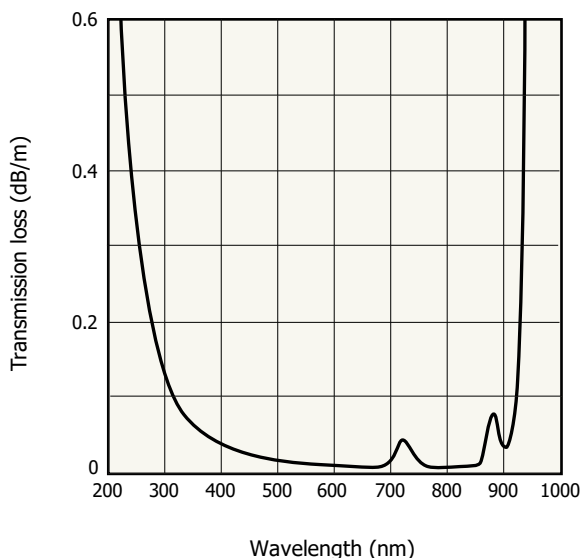

KACCB0079EB

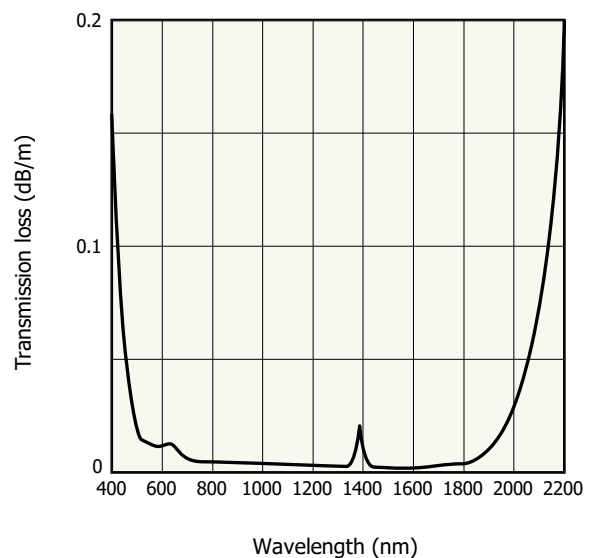

KACCB0080EA

(2) Light should be input to the optical fiber at an NA larger than the internal NA of the mini-spectrometer. If light is input to the optical fiber at an NA smaller than the internal NA of the mini-spectrometer, then problems such as wavelength shift may occur.

(3) The core diameter of the optical fiber should be about three times larger than the entrance slit width of the mini-spectrometer (when the input slit width is more than 70 μm). Measurement wavelength reproducibility deteriorates if the core diameter of the optical fiber is less than about three times the entrance slit width (When the input slit width is 70 μm or less, use an optical fiber with a core diameter of 200 μm or more.).

[Figure 2-18] Wavelength reproducibility vs. core diameter (optical fiber)

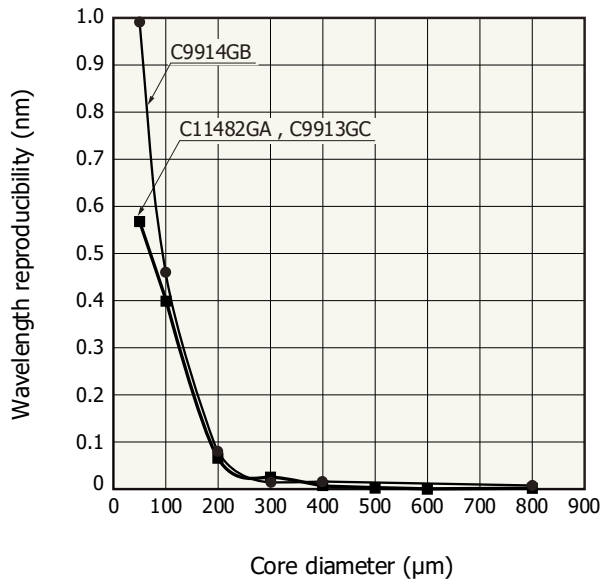

KACCB0112EF

[Figure 2-19] Slit height and optical fiber core diameter (example)

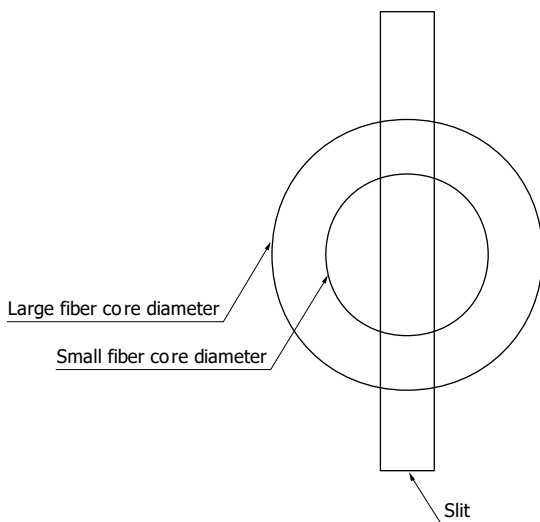

KACCC0546EA

(4) The protective tube surrounding the optical fiber should have good light shielding. If the protective tube of the optical fiber does not have good light shielding, then ambient light penetrates inside the optical fiber as stray light and affects measurement performance.

[Figure 2-20] Stray light measurement example using optical fibers having different light-shielding effects

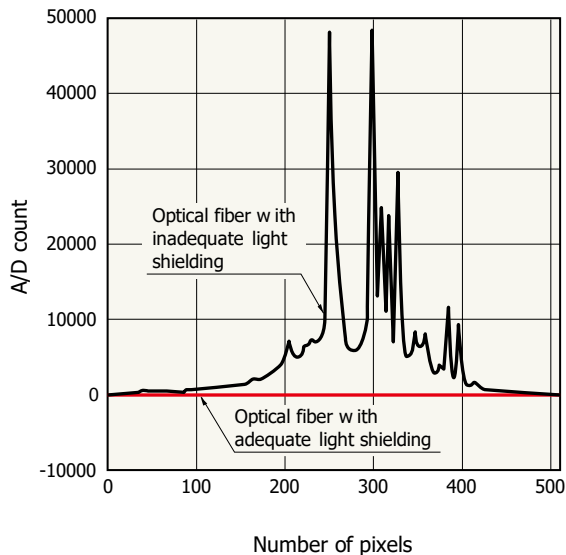

Optical fiber options

Hamamatsu provides optical fibers for use in the UV to visible range (UV resistant) or the visible to near IR range. These optical fibers (sold separately) are available in either 600 μm or 800 μm core diameters. See Mini-spectrometers selection guide page 17 for details.

https://www.hamamatsu.com/content/dam/hamamatsu-photonics/sites/documents/99_SALES_LIBRARY/ssd/mini-spectro_kacc0002e.pdf#page=17

- When the measurement spectral range includes wavelengths shorter than 400 nm, using the UV-VIS optical fiber is advisable.
- When using a mini-spectrometer whose slit height is 600 μm or more, the light level incident on the mini-spectrometer can be increased by selecting an 800 μm core diameter optical fiber. Please note however that specifications in the datasheet show data obtained when a 600 μm core diameter optical fiber is connected.

2-7. Driver circuit

Module type mini-spectrometers contain a driver circuit specifically designed for image sensors. The video signal processed by the video signal processing circuit in the driver circuit is converted into a digital signal by the 16-bit A/D converter and then transferred via the USB interface to a PC by the internal controller.

The driver circuit in these mini-spectrometers consists of the following sections.

Non-cooled type

- Sensor driver circuit
- Video signal processing circuit
- A/D converter
- Controller
- Data transfer section
- Power supply circuit

Cooled type

- Sensor driver circuit
- Video signal processing circuit
- A/D converter

- Controller
- Data transfer section
- Power supply circuit
- Temperature controller and cooling fan

(1) Sensor driver circuit

This driver circuit generates signals (CLK, START, RESET, etc.) according to each mini-spectrometer's image sensor specifications and inputs them to the image sensor terminals.

(2) Video signal processing circuit

The video signal processing circuit processes the video signal output from the image sensor. It adjusts the offset voltage and amplifies the output signal in order to maximize A/D converter performance in the mini-spectrometer.

(3) A/D converter

This A/D converter converts the video signal output from the video signal processing circuit into a 16-bit digital signal.

(4) Controller

This controller performs data transfer to/from the sensor and also generates a scan start signal at the optimal timing.

(5) Data transfer section

Data converted by the A/D converter is stored in the FIFO memory of the sensor driver circuit and then transferred to a PC through the USB interface via the internal RAM of the CPU asynchronously along with the sensor scan.

(6) Power supply circuit

This power supply circuit receives USB bus power from a PC and external power to generate the voltages required for the internal DC/DC converter. To keep circuit noise to a minimum, a filter circuit functions to minimize switching noise generated in the PC and DC/DC converter.

(7) Temperature controller and cooling fan

In cooled type mini-spectrometers, a thermoelectric cooler assembled into the image sensor cools the sensor photosensitive area to make accurate measurements at lower dark current. The temperature controller controls the current flowing to the thermoelectric cooler to maintain the sensor photosensitive area at a constant temperature. The cooling fan efficiently dissipates heat from the thermoelectric cooler.

2-8. Interface

Mini-spectrometers are grouped into module type and equipment assembly type. The module type supports a USB interface as shown in Table 2-4 .

[Table 2-4] USB interfaces of module type mini-spectrometers

Mini-spectrometer	Type no.	Interface
TG/TG-cooled series	C9405CC, C9913GC, C9914GB	USB 1.1
TG2/TG-cooled2 series	C11118GA, C11482GA	USB 2.0
TM series	C10082MD, C10082CA, C10082CAH C10083MD, C10083CA, C10083CAH	USB 1.1
TM2 series	C11697MB	USB 2.0
TF series	C13053MA, C13555MA, C14486GA	USB 2.0
WS series	C16449MA-01, C16449MA-02	USB 2.0

(1) Module type

Module type mini-spectrometers include an optical system, an image sensor, and a driver circuit, etc. They also have a USB interface (USB 1.1 or 2.0) for connecting to a PC. Evaluation software that comes with the mini-spectrometer allows setting the image sensor operating conditions (integration time, gain, etc.) as well as acquiring data from the image sensor.

[Figure 2-21] Block diagram (C10082MD)

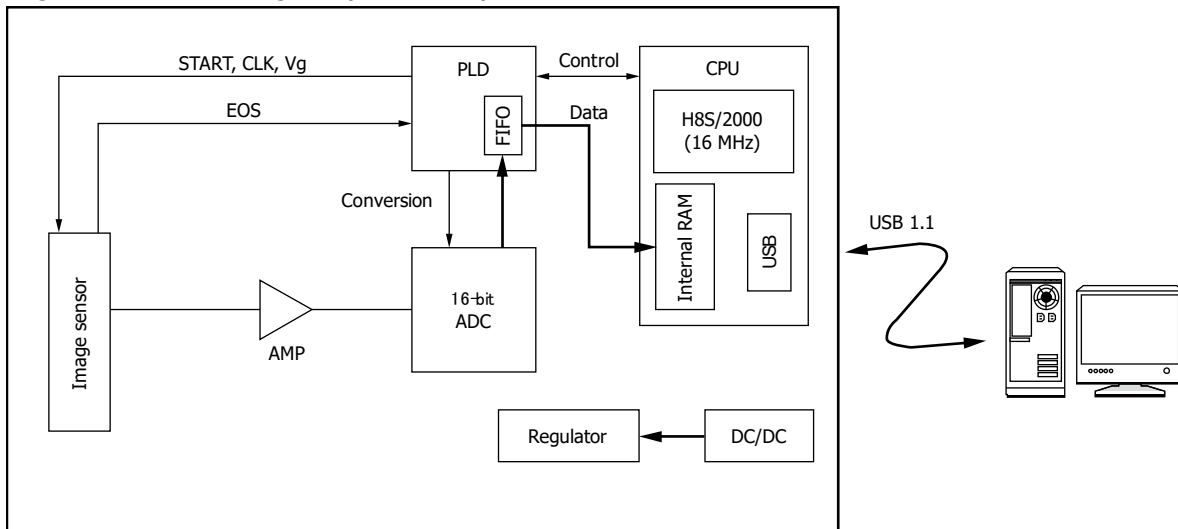

KACCC0251EA

[Figure 2-22] Mini-spectrometer to PC connection example

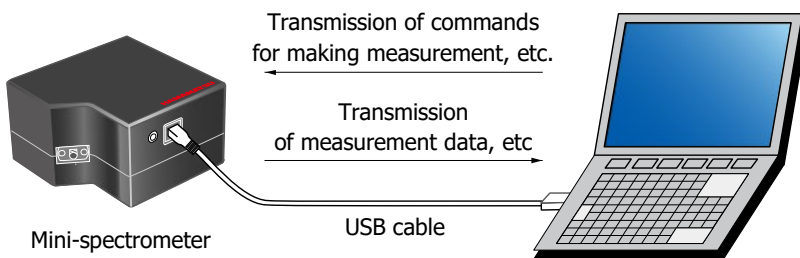

KACCC0657JA

[Figure 2-19] Software configuration concept view

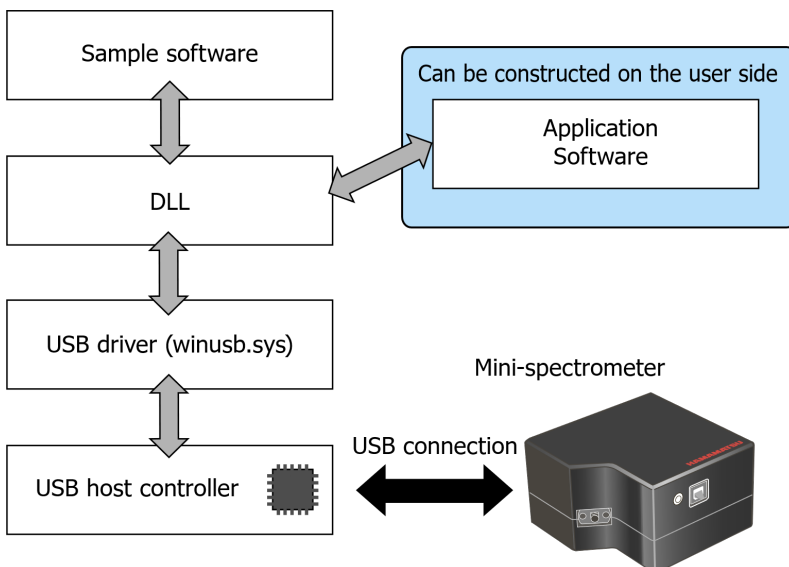

KACCC0658ED

(2) Equipment assembly type

Equipment assembly type mini-spectrometers include an optical system and an image sensor. The input/output terminals of the image sensor are connected to the external circuit. These mini-spectrometers allow the user to configure a system with an optional circuit design that matches the application.

[Table 2-5] Connection method of equipment assembly type mini-spectrometers

Mini-spectrometer	Connection method
C10988MA-01, C10988MA-02, C11708MA, C12666MA, C12880MA, C16767MA, C16767MA-01	IC pins

2-9. Evaluation software

The dedicated evaluation software supplied with a module type mini-spectrometer allows easy operation of the mini-spectrometer from a PC via a USB connection. Software performs tasks such as measurement data acquisition and save.

(1) Functions

Installing the evaluation software*¹ into your PC allows running the following basic tasks:

- Measurement data acquisition and save
- Measurement condition setting
- Module information acquisition (wavelength conversion factor*², mini-spectrometer type, etc.)
- Graphic display
- Arithmetic functions

[Pixel number to wavelength conversion, comparison calculation with reference data (transmittance, reflectance), dark subtraction, Gaussian approximation (peak position and count, FWHM)]

*1: Refer to [Table 2-6] Evaluation software for compatible OS.

*2: Conversion factors for converting the image sensor pixel number into a wavelength. Calculation factors for converting the A/D converted count into a value proportional to the light level are not provided.

Note: Two or more mini-spectrometers can be connected to one PC (except for MS series and micro-spectrometers).

The following six types of evaluation software are available. Each type of evaluation software can only be used on the specified mini-spectrometers.

- For TG/TM/TG-cooled series (interface: USB 1.1)
- For TG2/TG-cooled2/TM2/TF series (interface: USB 2.0)
- For MS series
- For C12880MA
- For C13895
- For WS series

[Figure 2-25] Screenshots of evaluation software

(a) For TG/TM/TG-cooled series

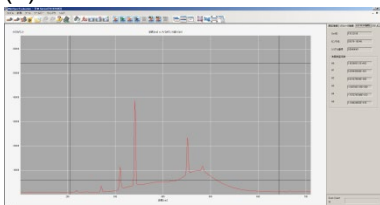

(b) For TG2/TG-cooled2/TM2/TF series

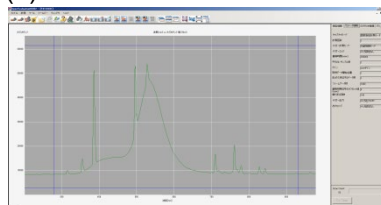

(c) For MS series

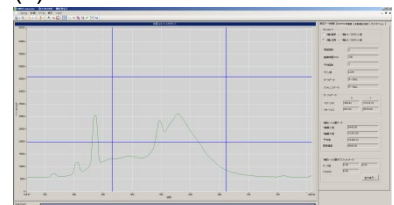

(d) For C12880MA

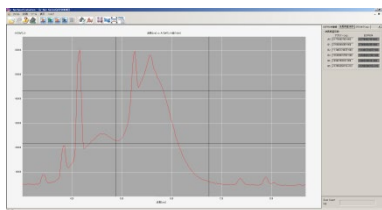

(e) For C13895MA

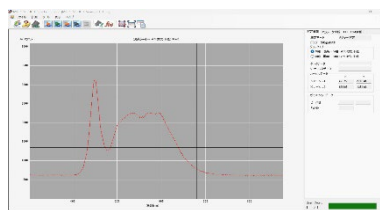

(f) For WS series

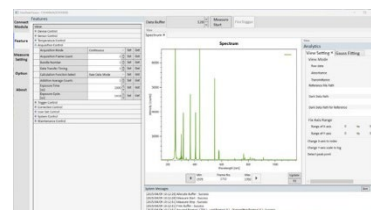

The mini-spectrometer comes with a DLL that serves as an intermediary between the application and software and the hardware, as well as evaluation software and sample software that utilize the DLL. All of these are available for download. Use the DLL when controlling the mini-spectrometer from the evaluation software. On the application software it is not possible to directly access the I/O and memory, so the necessary functions must be called up from the DLL to control the mini-spectrometer via the device driver and USB interface. Users can also develop their own application software by using the DLL.

The DLL and evaluation software differ according to the mini-spectrometer model. The function specifications and a software instruction manual are stored in the folder of the download software. If you want to obtain them before purchasing the mini-spectrometer, please contact us.

[Table 2-6] Evaluation software

Mini-spectrometers	DLL	Evaluation software	Supported OS	Notes
C9405CC C9913GC, C9914GB C10082MD, C10082CA C10082CAH C10083MD, C10083CA C10083CAH	specu1b.dll	SpecEvaluation.exe	Windows 10 Professional (64-bit), Windows 11 Professional	Supports simultaneous connections of multiple devices.
C11118GA, C11697MB C13053MA, C13555MA	HSSUSB2A.dll	SpecEvaluationUSB2.exe		
C16449MA-01 C16449MA-02	HiasApi.dll	HiasDataViewer.exe	Windows 11 Professional (64-bit)	
C13016 (Evaluation circuit for C12880MA) C13895	MICRO_USB2_CLR.dll	u-ApsSpecEvaluation.exe	Windows10 Professional (32-bit, 64-bit), Windows11 Professional	-

(2) Measurement mode

The evaluation software has four measurement modes: "Monitor" mode, "Measure" mode, "Dark" mode, and "Reference" mode. Table 2-7 describes each measurement mode.

[Table 2-7] Measurement modes of evaluation software

Measurement mode	Description	Features
Monitor mode	Measurement mode for monitoring without saving measurement data	Graphically displays "pixel numbers vs. A/D output count" data in real time
		Graphically displays "wavelength vs. A/D output count" data in real time
		Graphically displays time-series data at a selected wavelength*2
		Cannot save measurement data
		Performs dark subtraction
		Displays reference data
Measure mode	Measurement mode for acquiring and saving data	Graphically displays "pixel number vs. A/D output count" data in real time
		Graphically displays "wavelength vs. A/D output count" data in real time
		Graphically displays time-series data at a selected wavelength*2
		Saves measurement data
		Performs dark subtraction
		Displays reference data
Dark mode*1	Measurement mode for acquiring dark data (used for dark subtraction)	Graphically displays "pixel number vs. A/D output count" data in real time
		Graphically displays "wavelength vs. A/D output count" data in real time
		Saves measurement data
Reference mode*1	Measurement mode for acquiring reference data	Graphically displays "pixel number vs. A/D output count" in real time
		Graphically displays "wavelength vs. A/D output count" in real time
		Saves measurement data
Trigger mode*2	Measurement mode for acquiring data by trigger signal	Software trigger, asynchronous measurement
		Software trigger, synchronous measurement
		External trigger, asynchronous edge
		External trigger, asynchronous level
		External trigger, synchronous edge
Continuous measurement mode*2	Continuous data acquisition by batch data transfer	Graphically displays "pixel number vs. A/D output count" data at completion of data transfer
		Graphically displays "wavelength vs. A/D output count" data at completion of data transfer
		Saves measurement data

*1: "Dark" mode and "Reference" mode are not provided for the C11118GA, C11697MB, C13555MA, C11482GA, C14486GA and C13016. "Measure" mode has equivalent functions.

*2: Only supported by the C11118GA, C11697MB, C13053MA, C13555MA, and C13016

Note: C16449MA-01 and C16449MA-02 are different from the measurement modes mentioned above.

For details, refer to the instruction manual supplied with the product.

(3) Arithmetic functions of evaluation software

The evaluation software can perform the following arithmetic functions.

[Table 2-8] Arithmetic functions of evaluation software

Arithmetic function	Features
Dark subtraction	Measures dark data and subtracts it from measurement data.
Reference data measurement and display	Measures reference data and displays it graphically
Gaussian fitting	Fits data in a specified range to Gaussian function

(4) Data save

The evaluation software can save the data acquired in Measure mode, Dark mode, and Reference mode in the following file format.

[Table 2-9] File format in which evaluation software can save data

File format	Feature
CSV format	Can be loaded on Microsoft® Excel®

Note: Microsoft and Excel are the registered trademarks of Microsoft Corporation in the U.S. and other countries.

3. Characteristics

3-1. Spectral response range

The spectral response range is a wavelength range in which an output peak is observed when spectral lines are input to the mini-spectrometer. Hamamatsu offers a wide lineup of mini-spectrometers with different spectral response characteristics in the UV to infrared range.

3-2. Free spectral range

The free spectral range is the wavelength range in which a spectrum can be measured without effects from high-order diffraction light, such as -2nd and -3rd order light, by utilizing a filter. Spectral optical design based on -1st order light makes it possible to provide a free spectral range. Spectral response ranges of Hamamatsu mini-spectrometers match the free spectral range.

When the following condition is met:

$$\frac{\text{Upper limit of spectral response range}}{\text{Lower limit of spectral response range}} > 2$$

This case generates high-order diffraction light due to structure. A high-pass filter is therefore installed in the mini-spectrometers to eliminate this high-order diffraction light.

When the following condition is met:

$$\frac{\text{Upper limit of spectral response range}}{\text{Lower limit of spectral response range}} \leq 2$$

Here also, when light at a wavelength shorter than the spectral response range enters, the incident light might be mistakenly measured as -2nd order light. When light at a wavelength for example of 800 nm enters the C11482GA (spectral response range: 900 to 1700 nm) along with the measurement light, a -2nd order light of 800 nm might be detected around 1600 nm, and this may cause problems. If this happens, a long-pass filter (in this case a 900 nm long-pass filter) must be used with the optical system to meet free spectral range conditions.

3-3. Spectral resolution

(1) Definition

There are two methods for defining the spectral resolution. One method uses the Rayleigh criterion in DIN standards. The spectral resolution in this method is defined by a numerical value that indicates how finely the mini-spectrometer can distinguish the wavelength difference between two adjacent peaks having the same intensity simultaneously. In this case, the valley between the two peaks must be lower than 81% of the peak value. On the other hand, a more well-known and practical alternative is defining the spectral resolution as the spectral half-width or FWHM (full width at half maximum). This is the spectral width at 50% of the peak value and directly defines the extent of spectral broadening. The spectral resolution defined as FWHM is approximately 80% of the resolution defined by the Rayleigh criterion. The spectral resolution of Hamamatsu mini-spectrometers is defined by FWHM.

[Figure 3-1] Resolution defined by Rayleigh criterion

[Figure 3-2] Definition of FWHM

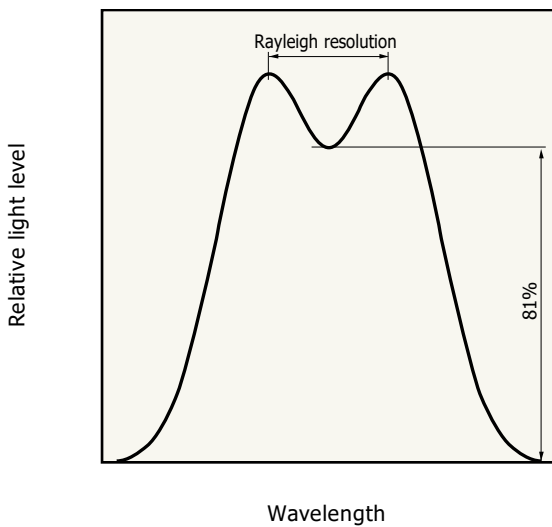

KACCC0545EA

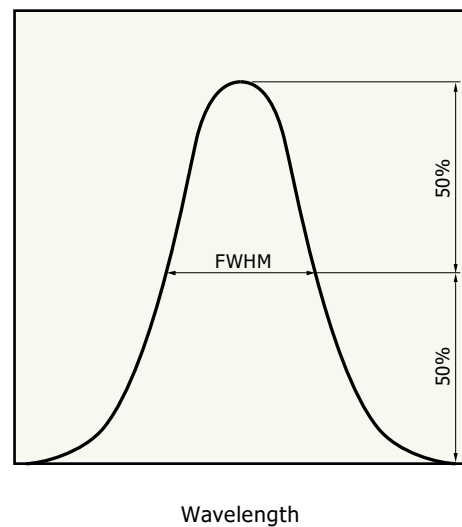

KACCC0320EB

[Figure 3-3] Spectral resolution vs. wavelength (typical example)

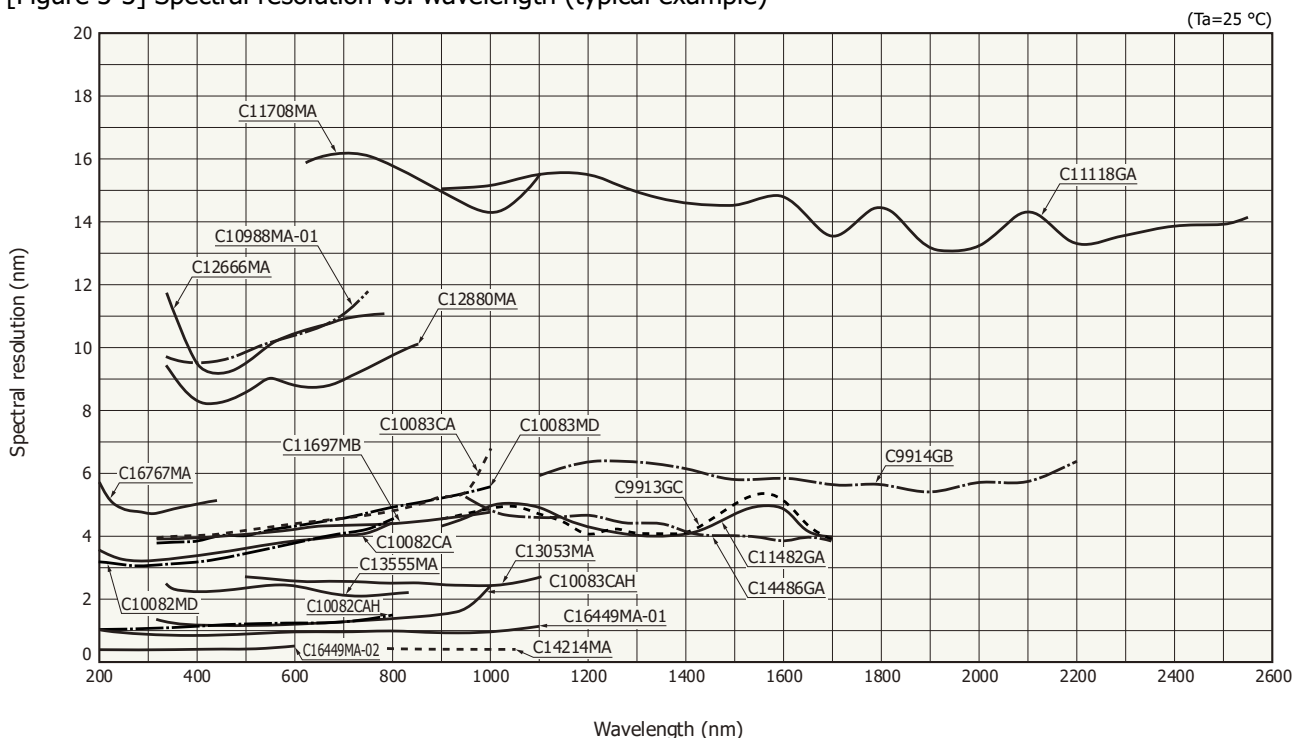

KACCB0139ES

(2) Factors that determine spectral resolution Spectral resolution of mini-spectrometers is determined by the following factors:

- Entrance slit width
- Internal NA of mini-spectrometer
- Lattice frequency of grating
- Focus magnification of optical systems

There are some methods to improve the spectral resolution: narrowing the entrance slit width, making the internal NA of the mini-spectrometer smaller, and setting the lattice frequency higher. However, narrowing the entrance slit width reduces the throughput of the mini-spectrometer. Increasing the lattice frequency of the grating usually requires making the equipment larger or narrows the spectral response range. So please note that this requires a trade-off in specifications.

3-4. Wavelength accuracy

Wavelength calibration is usually performed using the light output from a monochromator or spectral line lamp. Hamamatsu uses a monochromator. When using a monochromator, the wavelength accuracy of the monochromator affects the absolute wavelength accuracy of mini-spectrometers, so the monochromator wavelength must be calibrated in advance to a high degree of precision.

When Gaussian-fitting the wavelength calibration result, a high-order approximation expression is commonly used. The higher the order of the approximation expression, the higher the fitting accuracy will be. However, satisfactory accuracy can usually be obtained with a 5-order approximation expression. Figure 3-4 shows an example of fitting errors during fitting of the C10082MD mini-spectrometer with a 5-order approximation expression.

[Figure 3-4] Wavelength calibration fitting error example (by 5-order approximation expression for C10082MD)

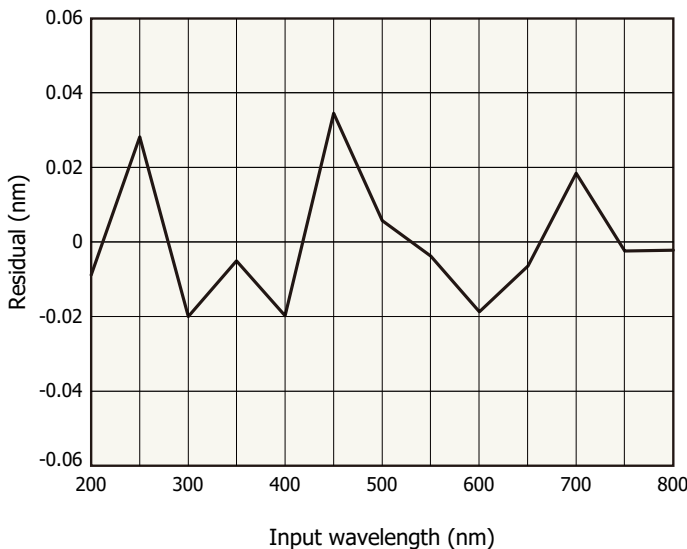

KACCB0282EA

3-5. Wavelength reproducibility

Mini-spectrometers have excellent wavelength reproducibility (± 0.1 nm to ± 0.8 nm) because they contain no mechanical moving parts. Hamamatsu mini-spectrometers use a rugged optical system having materials with extremely low coefficient of thermal expansion and so provide low temperature dependence (± 0.01 to ± 0.08 nm/ $^{\circ}\text{C}$).

It is also necessary to take into account the wavelength shifts caused by the optical fiber. Wavelength shifts are caused by the core eccentricity of the optical fiber, changes in the fiber forming, or shifts in the optical axis or incident NA at the optical fiber input. To eliminate effects from core eccentricity, wavelength calibration must be performed while the optical fiber is connected to the mini-spectrometer.

3-6. Stray light

Stray light is generated due to extraneous light (which should not be measured) entering the image sensor. The following factors can generate stray light.

- Fluctuating background light
- Imperfections in the grating
- Surface reflection from lens, detector window, and detector photosensitive area

There are two methods to define stray light. One method utilizes a long-pass filter while the other method utilizes reference light in a narrow spectral range (light output from a monochromator or line spectra emitted from a spectral line lamp, etc.).

The long-pass filter method uses white light obtained by passing through a long-pass filter for particular wavelengths. In this case, the stray light is defined as the ratio of transmittance in the "wavelength transmitting" region to transmittance in the "wavelength blocking" region. The stray light level (SL) is expressed by equation (3-1). (See Figure 3-5 for definitions of TI and Th.)

$$SL = 10 \times \log (T_I/T_H) \dots\dots\dots (3-1)$$

This definition allows measuring the effects from stray light over a wide spectral range and so is a suitable evaluation method for actual applications such as fluorescence measurement. However, be aware that the intensity profile of the white light used as reference light will affect the measurement value.

[Figure 3-5] Definitions of TI and Th

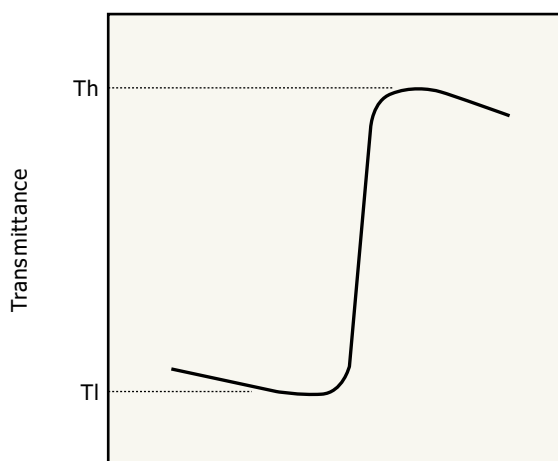

KACCC0255EA

In the other method using reference light in a narrow spectral range, the stray light level (SL) is expressed by equation (3-2).

$$SL = 10 \times (\log IM/IR) \dots\dots\dots (3-2)$$

IM: unwanted light level that was output at wavelengths deviating from the reference light spectrum
 IR: reference light level

In this definition, the measurement conditions are very simple and so allow high reproducibility when quantitatively evaluating the stray light of mini-spectrometers.

When using a long-pass filter or a narrow spectrum, it is necessary to consider the fact that the stray light differs depending on the wavelength of detected light. The stray light of mini-spectrometers should therefore be measured at multiple wavelengths.

[Figure 3-6] Stray light measurement examples using line spectra (averaged over 100 measurements)

(a) C10082MD

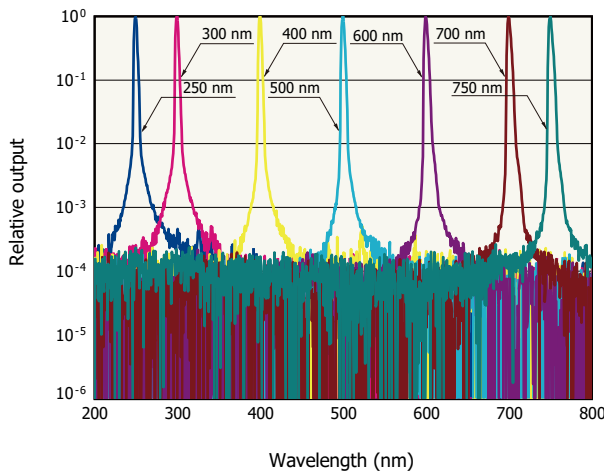

KACCB0281EA

(b) C9914GB

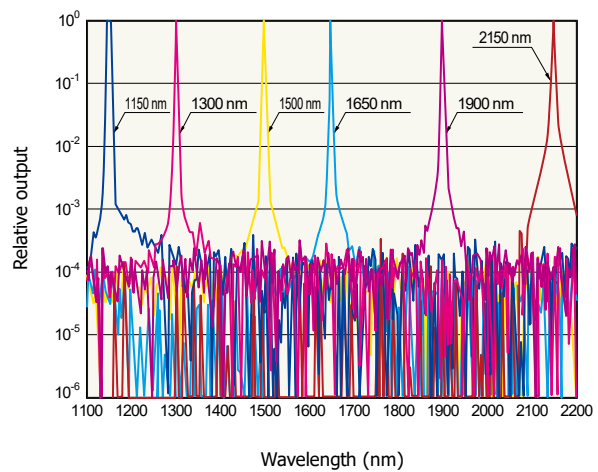

KACCB0119EA

3-7. Sensitivity

The output charge of an image sensor mounted in mini-spectrometers is expressed by equation (3-3).

$$Q(\lambda) = k(\lambda) \cdot P(\lambda) \cdot T_{exp} \dots\dots\dots (3-3)$$

Q(λ) : image sensor output charge [C]

k(λ) : conversion factor for converting the light level entering a mini-spectrometer into image sensor output charge

-(=optical system efficiency × diffraction efficiency of grating × image sensor sensitivity)

p(λ) : incident light level [W] at each wavelength incident on a mini-spectrometer

T_{exp} : integration time [s]

The output charge Q(λ) of an image sensor is converted into a voltage by the charge-to-voltage converter circuit and then converted into a digital value by the A/D converter. This is finally derived from the mini-spectrometer as an output value. The output value of a mini-spectrometer is expressed by equation (3-4).

$$I(\lambda) = \varepsilon \cdot Q(\lambda) = \varepsilon \cdot k(\lambda) \cdot P(\lambda) \cdot T_{exp} \dots\dots\dots (3-4)$$

I(λ) : mini-spectrometer output value [counts]

ε : conversion factor for converting image sensor output charge into a mini-spectrometer output value (equals the product of the charge-to-voltage converter circuit constant and the A/D converter resolution)

The sensitivity of a mini-spectrometer is expressed by equation (3-5).

$$E(\lambda) = I(\lambda) / \{P(\lambda) \cdot T_{exp}\} \dots\dots\dots (3-5)$$

$E(\lambda)$: sensitivity of mini-spectrometer [counts/(W·s)]

Substituting equation (3-4) into (3-5) gives:

$$E(\lambda) = \varepsilon \cdot k(\lambda) \dots\dots\dots (3-6)$$

[Table 3-1] Wavelength dependence of parameters that determine conversion factor

Parameter determining conversion factor	Wavelength dependence
Optical system efficiency	Yes
Diffraction efficiency of grating	Yes
Image sensor sensitivity	Yes
Charge-to-voltage converter circuit constant	No
A/D converter resolution	No

The graph of mini-spectrometer spectral response is expressed in terms of peak values that are approximated by the Gaussian function when spectral lines are input. Please note that the spectral response may differ from those shown in Figure 3-7 when light covering a wide spectral band enters the mini-spectrometer.

[Figure 3-7] Spectral response

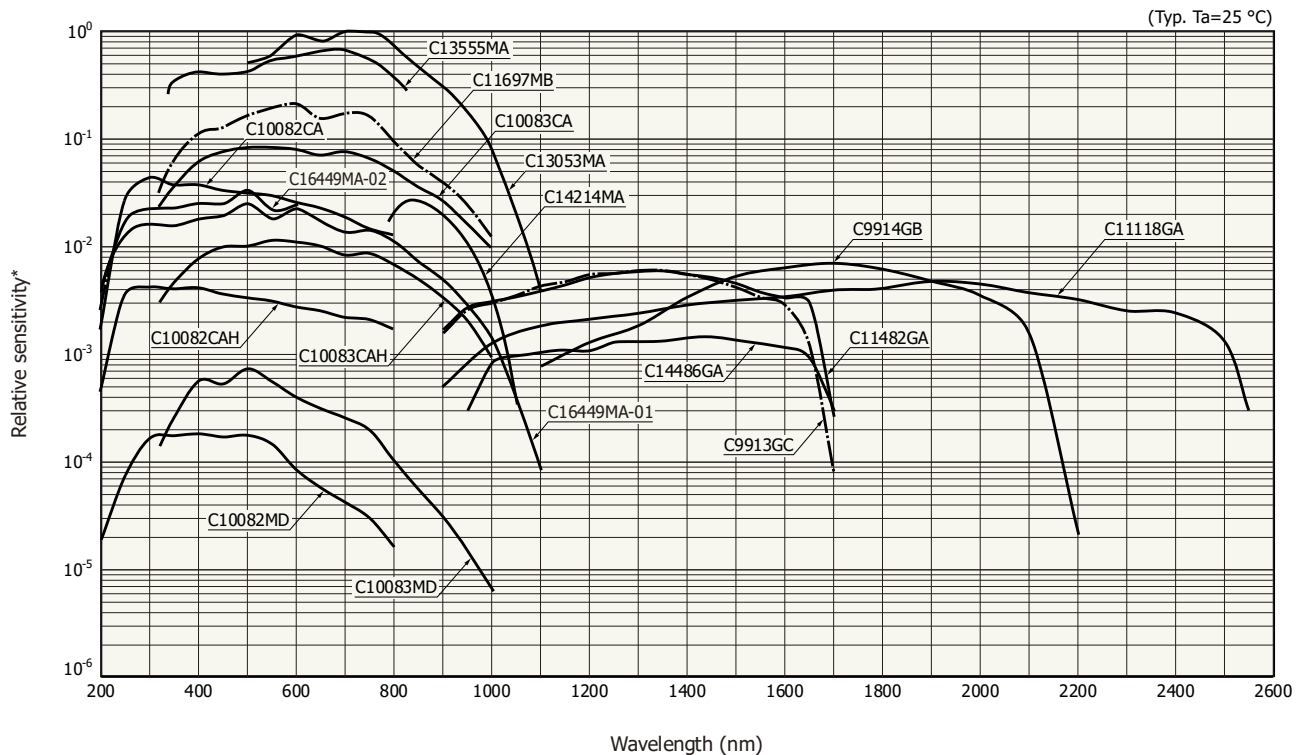

* A/D count when constant light level enters optical fiber
(Fiber core diameter: 600 μm, assuming no attenuation in optical fiber)

KACCB0137ER

3-8. Dynamic range

The dynamic range of mini-spectrometers is grouped into the following types. Examples for calculating these dynamic ranges are described below.

- Output dynamic range
- Light level dynamic range
- Dynamic range limited by dark output
- Dynamic range limited by shot noise

- Dynamic range relating to linearity

(1) Output dynamic range

Because the output dynamic range of the module type mini-spectrometers is affected by circuit noise and A/D converter saturation, the dynamic range will be slightly smaller than that of the equipment assembly type as long as the same type of image sensor is used. If the circuit noise is sufficiently smaller than readout noise, then there are virtually no effects from circuit noise on the dynamic range.

a. Equipment assembly type

- Dynamic range = $\frac{\text{Saturation output voltage}}{\text{Readout noise}}$

b. Module type

$$\text{Dynamic range} = \frac{\text{Output voltage when A/D count is saturated}}{\sqrt{\{(\text{Readout noise})^2 + (\text{Circuit noise})^2\}}}$$

Example: If the output voltage is 2.4 V when the mini-spectrometer A/D count is saturated, and the image sensor readout noise is 0.2 mV rms, and the circuit noise is 0.1 mV rms, then the dynamic range is given as follows:

$$\text{Dynamic range} = 2400 / \sqrt{(0.2)^2 + (0.1)^2} = 10700$$

(2) Light level dynamic range

$$\text{Dynamic range} = \frac{(\text{at low gain}^{*1}) \text{ Light level just before A/D count is saturated at lower limit of integration time}}{(\text{at high gain}^{*2}) \text{ Light level at which spectral line can be checked at upper limit of integration time}^{*6}}$$

*1: When the gain can be set.

*2: For example, light level at which the A/D count output produced by the incident light is 3σ when the dark output variation at the integration time upper limit is σ .

The A/D count is the light output count after dark subtraction. The equipment assembly type is connected to the dedicated evaluation circuit to make measurements.

Example: If the light level just before the A/D count is saturated at the integration time lower limit during low gain is 40 mW, and the light level at which a spectral line can be checked at the integration time upper limit during high gain is 0.001 mW, then this dynamic range is given as follows:

$$\text{Dynamic range} = 40/0.001 = 4 \times 10^4$$

[Figure 3-8] A/D count vs. light level

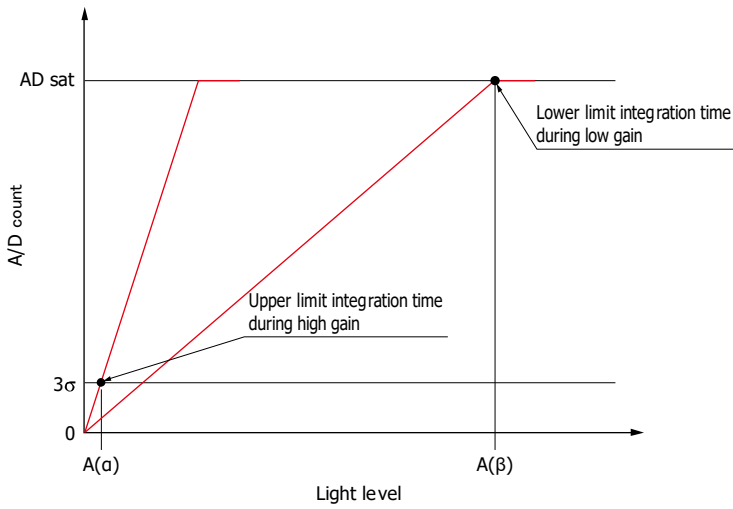

$$\text{Dynamic range} = A(\beta)/A(\alpha)$$

KACCC0549EA

(3) Dynamic range limited by dark output

a. Equipment assembly type

$$\text{Dynamic range} = \frac{\text{Saturation output voltage}}{\text{Dark output voltage per 1 ms integration time}}$$

Example: If the saturation output voltage is 2.5 V, and the dark output voltage is 1.6 mV, then this dynamic range will be:

$$2.5/1.6 \times 10^{-3} \approx 1.6 \times 10^3$$

b. Module type

$$\text{Dynamic range} = \frac{\text{Saturated A/D count} - \text{Offset A/D count}}{\text{Dark count per 1 ms integration time}}$$

Example: If the saturated A/D count is 65535, the offset A/D count is 1000, and the dark count per 1 ms is 0.2, then this dynamic range will be:

$$(65535-1000)/0.2 \approx 3.2 \times 10^5$$

The dynamic range varies with the ambient temperature since the dark voltage and dark count depend on the ambient temperature.

[Figure 3-9] Concept diagrams of output components

(a) Equipment assembly type

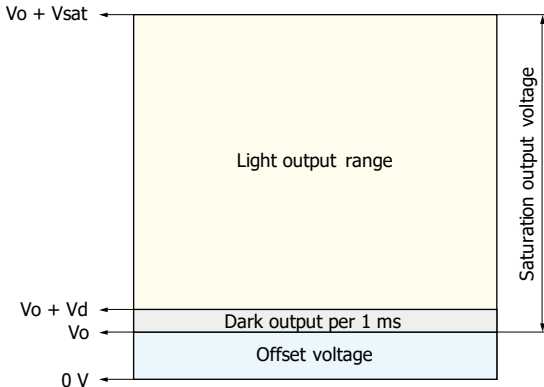

$$\text{Dynamic range} = \text{Vsat}/\text{Vd}$$

Vo: offset voltage
Vsat: saturation output voltage
Vd: dark voltage

KACCC0550EA

(b) Module type

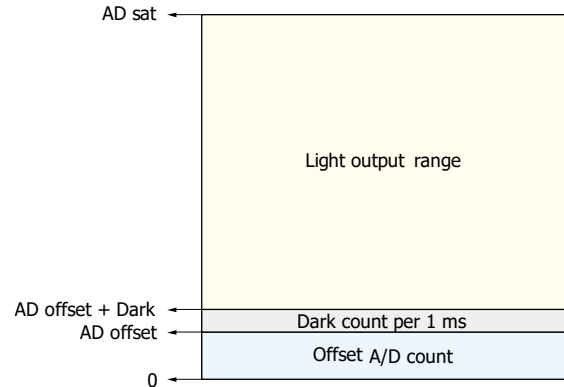

$$\text{Dynamic range} = (\text{AD sat} - \text{AD offset})/\text{Dark}$$

AD sat: saturation A/D count
AD offset: offset A/D count
Dark: dark count

KACCC0551EA

The dark voltage and dark count increase as the integration time becomes longer, and the dynamic range decreases. This means that dynamic range limited by the dark voltage and count can be extended by increasing the light level incident on the mini-spectrometer and setting the integration time shorter.

[Figure 3-10] Output vs. integration time

(a) Equipment assembly type

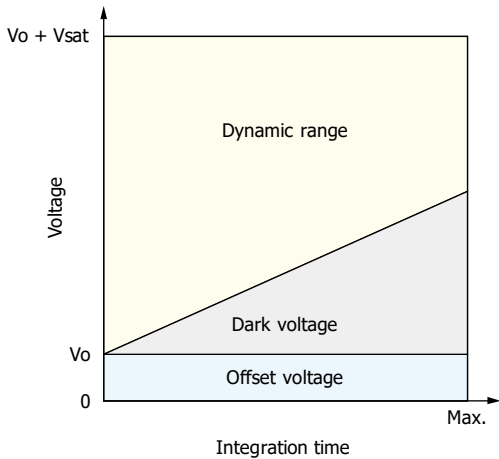

KACCC0552EA

(b) Module type

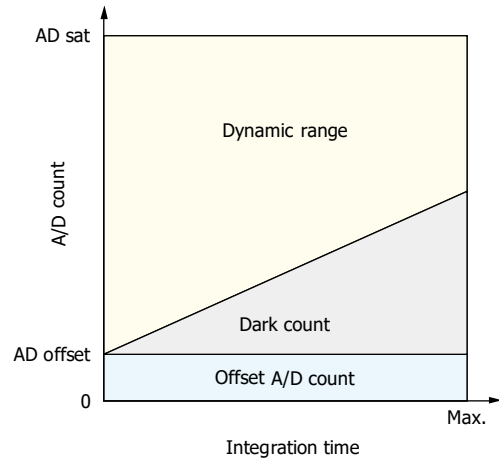

KACCC0553EA

(4) Dynamic range limited by shot noise

$$\text{Dynamic range} = \frac{\text{Number of signal electrons}}{\text{Shot noise}}$$

The shot noise (N_s) is expressed as the square root of the number of signal electrons (S).

$$N_s = \sqrt{S}$$

Example: If the number of saturated signal electrons is 200 ke^- , then this dynamic range is given as follows:

$$\text{Dynamic range} = S/N_s = 200 \text{ k} / \sqrt{200 \text{ k}} = \sqrt{200 \text{ k}} \approx 447$$

The number of saturated signal electrons in CMOS image sensors is significantly larger than in CCDs. Due to this reason, a CMOS image sensor has a better dynamic range limited by shot noise than a CCD.

[Figure 3-11] Relation between number of saturated electrons and shot noise

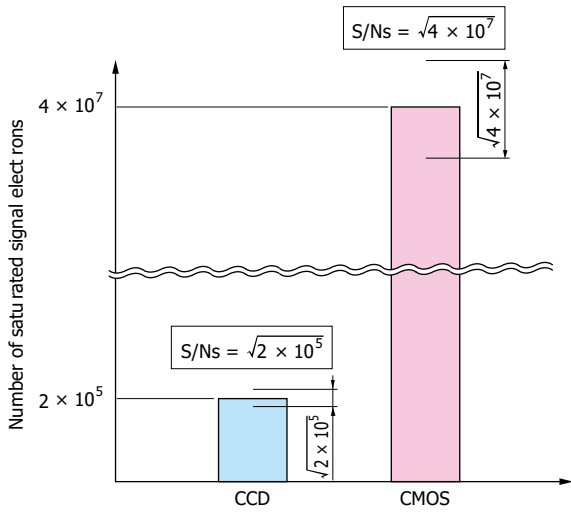

KACCC0554EA

(5) Dynamic range relating to linearity

When the A/D count output (or output voltage) at 1/2 of saturation is viewed as the reference point in an "A/D count vs. integration time" graph [Figure 3-12], this dynamic range is expressed as the ratio of the upper limit to the lower limit of integration time in which the deviation from the ideal line is within a specific range ($\pm 10\%$ in Figure 3-12). The A/D count used is the output count after dark subtraction.

[Figure 3-12] A/D count vs. integration time

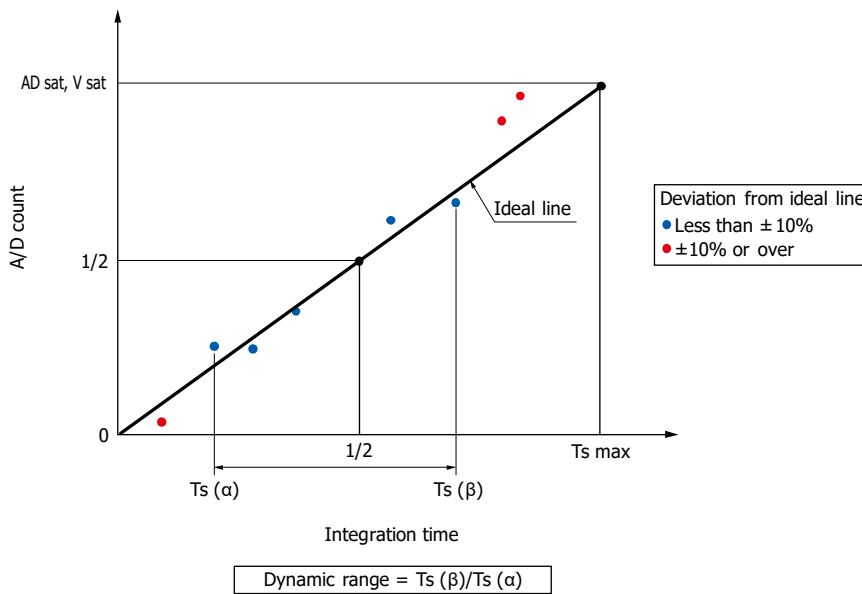

KACCC0555EA

4. Precautions when measuring laser beams

When measuring collimated light such as a laser beam, the measurement accuracy depends on the optical system used to guide the light to the mini-spectrometer. If only the reflective optical system is used to guide the laser beam into the input optical fiber of the mini-spectrometer, then the beam profile at the optical fiber exit end might become non-uniform. In this case, measurement accuracy can be improved by making the measurement light enter an integrating sphere and then guiding the diffused reflected light into the input optical fiber of the mini-spectrometer.

Table 4-1 shows peak wavelengths measured using a reflective optical system to guide a He-Ne laser output beam directly into the input optical fiber of the mini-spectrometer and also using an integrating sphere.

[Table 4-1] Peak wavelength measurement examples (C10082MD)

Item	Wavelength
He-Ne laser beam	632.8 nm
Peak wavelength measured using reflective optical system	634.9 nm
Peak wavelength measured using integrating sphere	632.5 nm

[Figure 4-1] Measurement method using reflective optical system

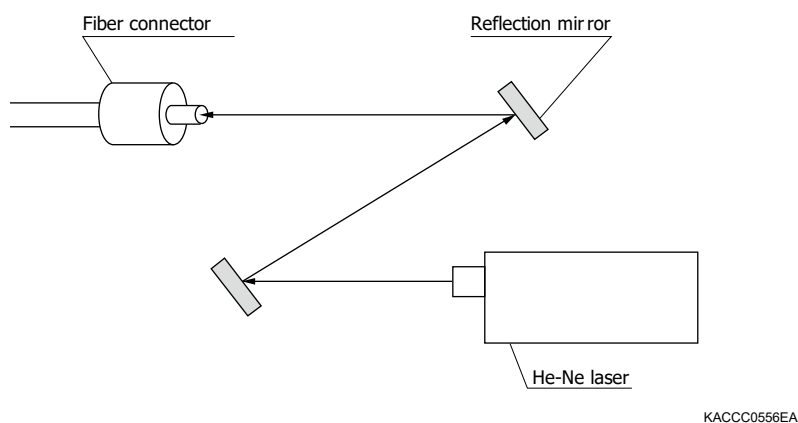

[Figure 4-2] Measurement method using integrating sphere

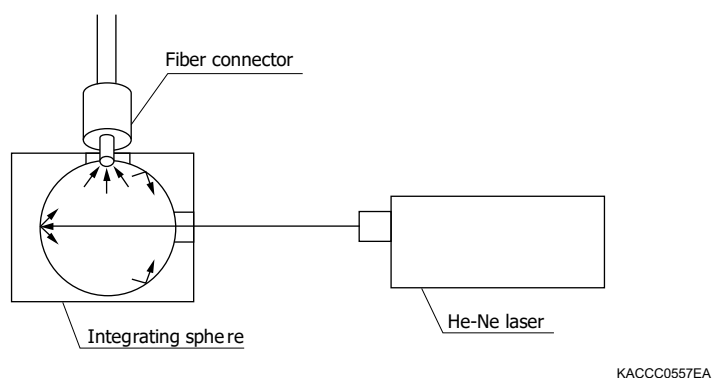

5. Cooled mini-spectrometer's dark output stability with variations in ambient temperature

(1) Dark output stability

Figure 5-1 shows how various parameters of the C9914GB varied when the ambient temperature was changed from 25 °C→0 °C→30 °C→25 °C. The image sensor temperature is the temperature measured with the built-in thermistor. It is seen that the image sensor temperature is controlled at -20 °C even when the ambient temperature was changed. The dark output, on the other hand, varies with the temperature inside the mini-spectrometer housing. This means that the dark output characteristics depend on the ambient temperature even though the image sensor temperature is accurately controlled.

[Figure 5-1] C9914GB temperature characteristics

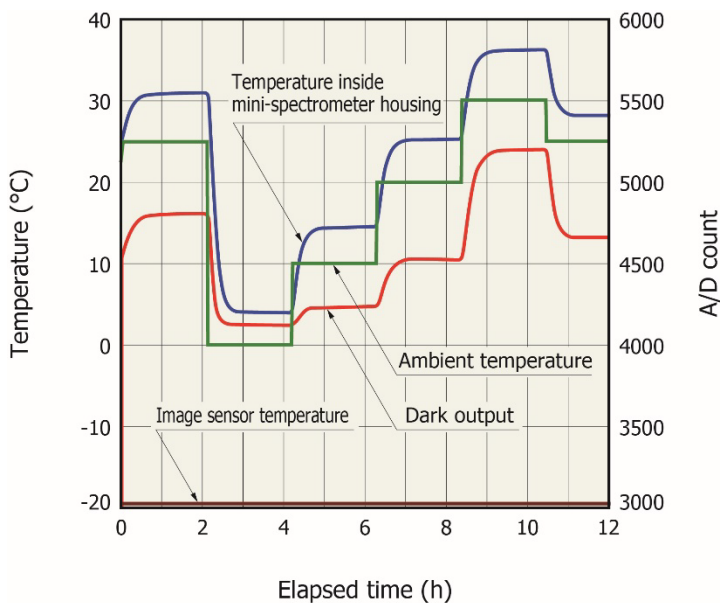

KACCB0283EA

(2) Effects of background radiation

Even though the image sensor temperature is controlled at -20 °C, the dark output varies due to the effects of background radiation. This is noticeable in detectors with sensitivity to wavelengths above 2.0 μm .

Note: Background radiation is electromagnetic radiation emitted from surrounding objects whose absolute temperature is above zero. This electromagnetic radiation propagates even in a vacuum and cannot be cancelled out by means based on the thermal conductance concept.

Figure 5-2 shows how the dark outputs of Hamamatsu image sensors with 1.7 μm , 2.05 μm and 2.15 μm cutoff wavelengths varied when the ambient temperature was changed in the range of 5 to 30 °C. The dark outputs of the image sensors with a longer cutoff wavelength vary more largely due to the effects of background radiation when the ambient temperature varies. To stabilize the mini-spectrometer dark output, the ambient temperature must be kept constant.

[Figure 5-2] Dark output temperature characteristics

(a) Image sensor with 1.7 μm cutoff wavelength

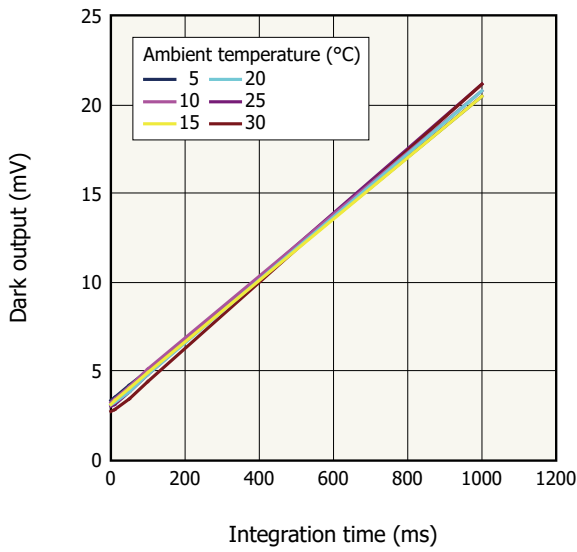

KACCB0284EA

(b) Image sensor with 2.05 μm cutoff wavelength

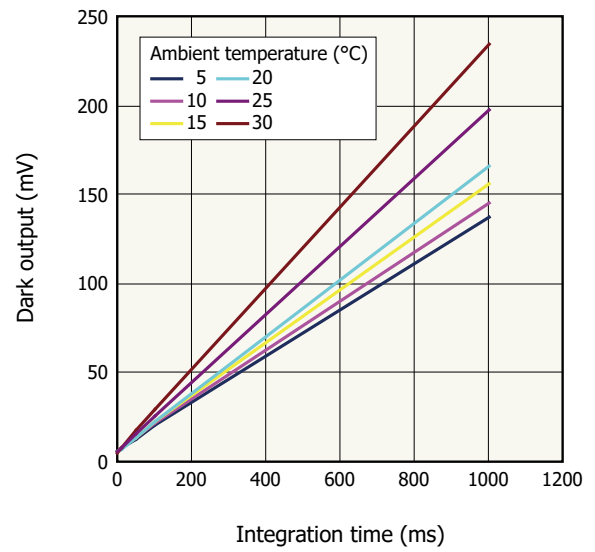

KACCB0285EA

(c) Image sensor with 2.15 μm cutoff wavelength

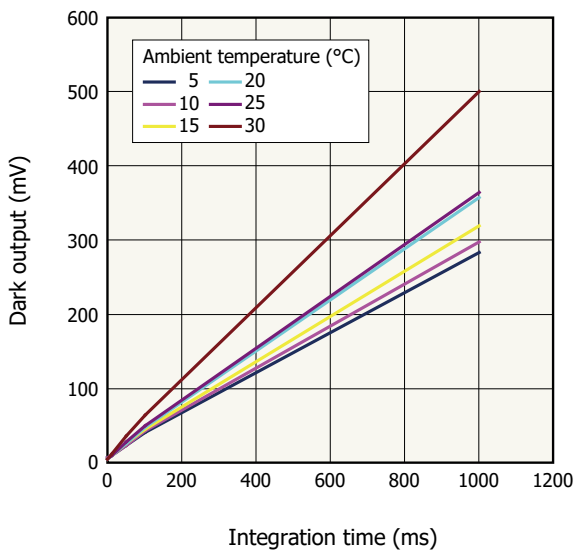

KACCB0286EA

Product specifications are subject to change without prior notice due to improvements or other reasons. This document has been carefully prepared and the information contained is believed to be accurate. In rare cases, however, there may be inaccuracies such as text errors. Before using these products, always contact us for the delivery specification sheet to check the latest specifications.

The product warranty is valid for one year after delivery and is limited to product repair or replacement for defects discovered and reported to us within that one year period. However, even if within the warranty period we accept absolutely no liability for any loss caused by natural disasters or improper product use. Copying or reprinting the contents described in this material in whole or in part is prohibited without our prior permission.